



Model: PD-F

## Pallet Dispenser/ Stacker

Pallet Dispensers are used to separate and dispense pallets, one at a time. The Pallet Dispenser features a magazine to hold a stack of empty pallets; pneumatic forks on each side that engage the stack, and an electric hydraulic scissor lift on the bottom. Often, an exit conveyor is also included. Typically, the exit conveyor is 2-strand C60 drag chain (model MSCC), but other conveyor options are available. Pallets are loaded in the magazine via a fork truck or an infeed conveyor. This equipment is a great way to maximize the efficiency of your production line.

### Speed/ Rate

- (3) pallets per minute

### Capacity

- 1,500 LB. load

### Magazine

- 6ft. high can accommodate 11 GMA pallets
- 8ft. high can accommodate 15 GMA pallets

### Infeed & Exit Configurations

- Discharge 90° left
- Discharge 90° right (*shown*)
- Discharge 180° rear

### Conveyor

- 2-strand C60 drag chain conveyor (model MSCC) with adjustable guardrail on both sides.
- Chain Centers: 36"
- Infeed elevation: 18"
- Optional:
  - Chain Driven Live Roller Conveyor (model CDLR)

### Conveyor Motor

- 3/4 HP up to 7.5 HP
- Inverter Duty
- Voltage: 230/460/ 3Ph/ 60hz
- Optional:
  - 115V/ 1Ph/ 60Hz
  - 208V/ 1Ph/ 60Hz
  - 230V/ 1Ph/ 60Hz
  - 575V/ 3Ph/ 60Hz

### Control Options

- PLC with HMI for automatic operation.
- Pushbutton controls for manual operation.
- No controls (provided by others).
- Note: All I/O points are pre-wired to junction box.

### Equipment Color

- Blue (RAL 5017)
- Guards are yellow (RAL 1023)
- Moving parts are bright red orange (RAL 2008)
- Optional:
  - Light Gray (RAL 7035)
  - Repose Gray (not an RAL)
  - Patina Green (RAL 6000)
  - Signal White (RAL 9003)
  - Jet Black (RAL 9005)
  - Flat Black (not an RAL)
  - Custom colors available

### Additional Options

- Fork Truck Barrier
- Wheel Chocks
- Custom sizes and features available. Please consult a LEWCO Applications Engineer for more information.

### Quality Assurance

- Each unit comes complete with a (2) year warranty.
- Manufactured under ISO 9001 Quality Certified System.

# Infeed & Exit Configurations Options

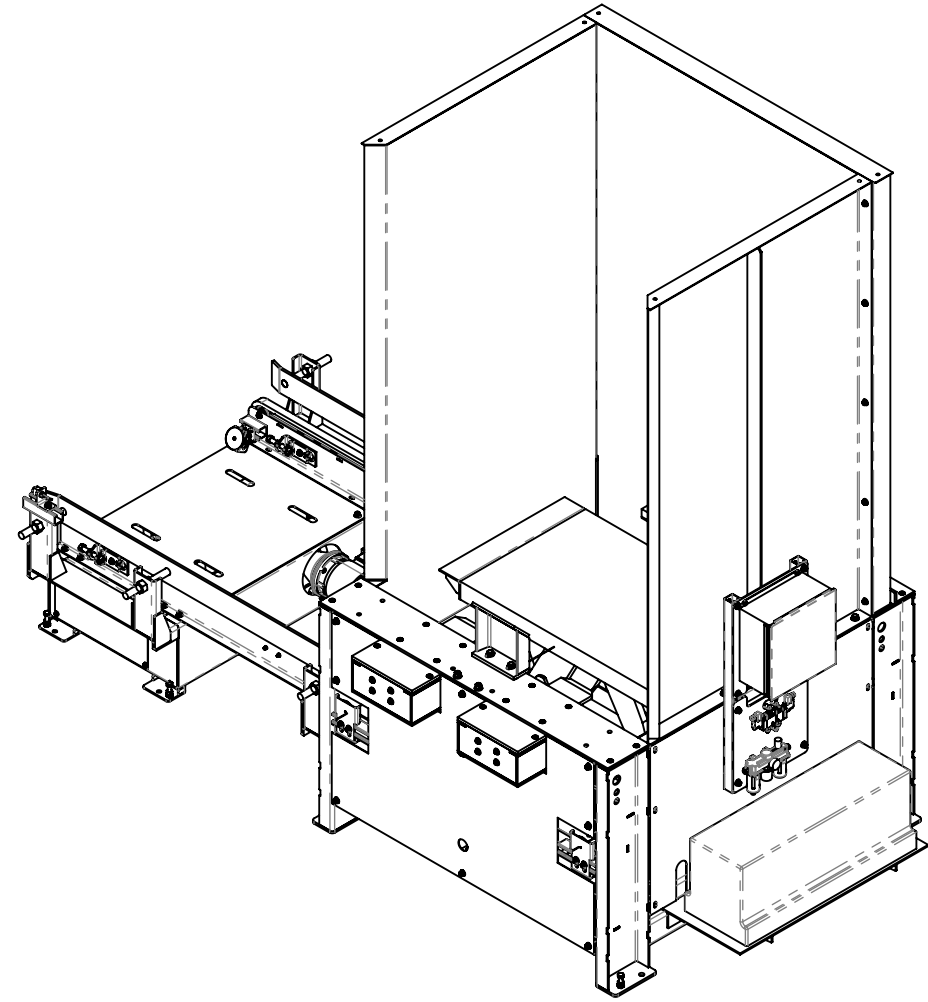

Model: PD-F-90L

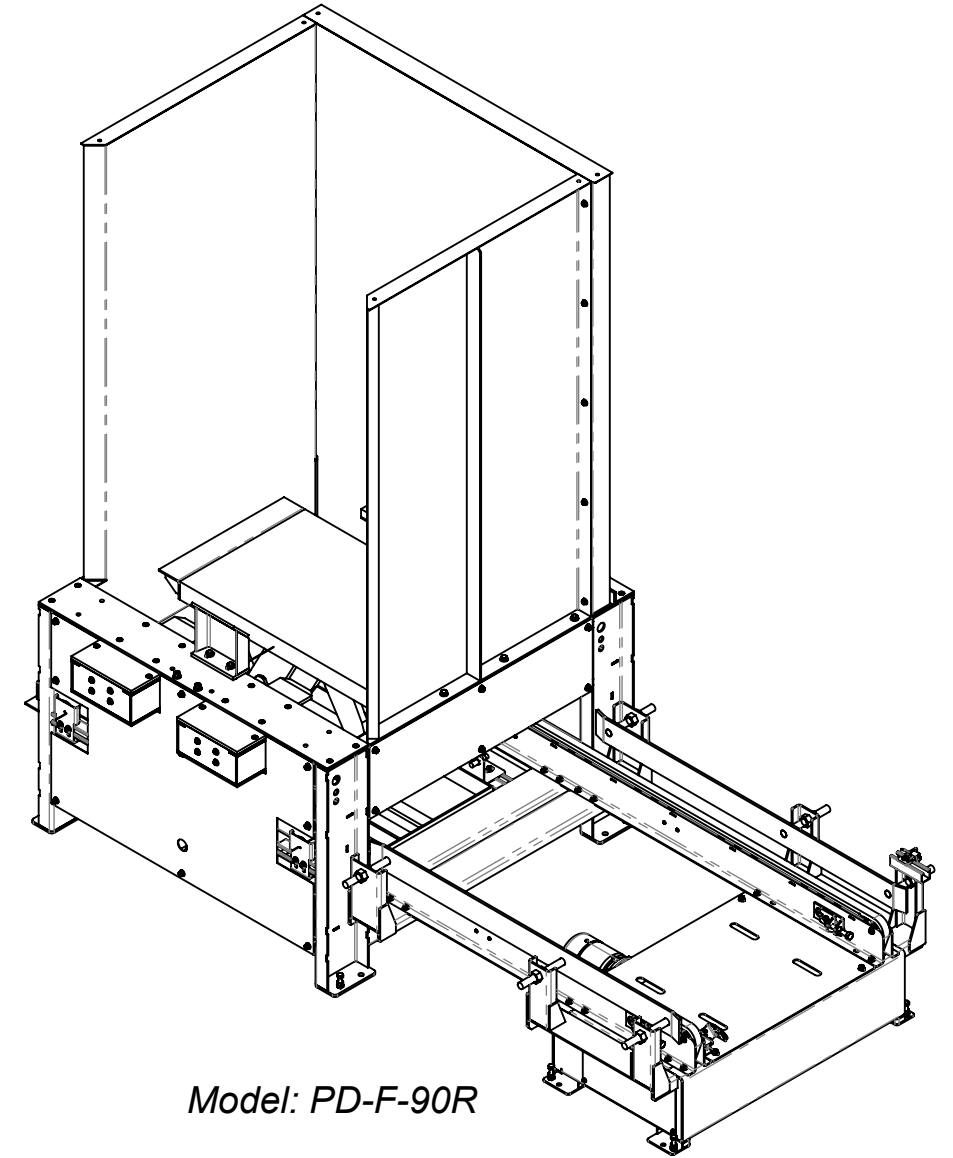

Model: PD-F-90R

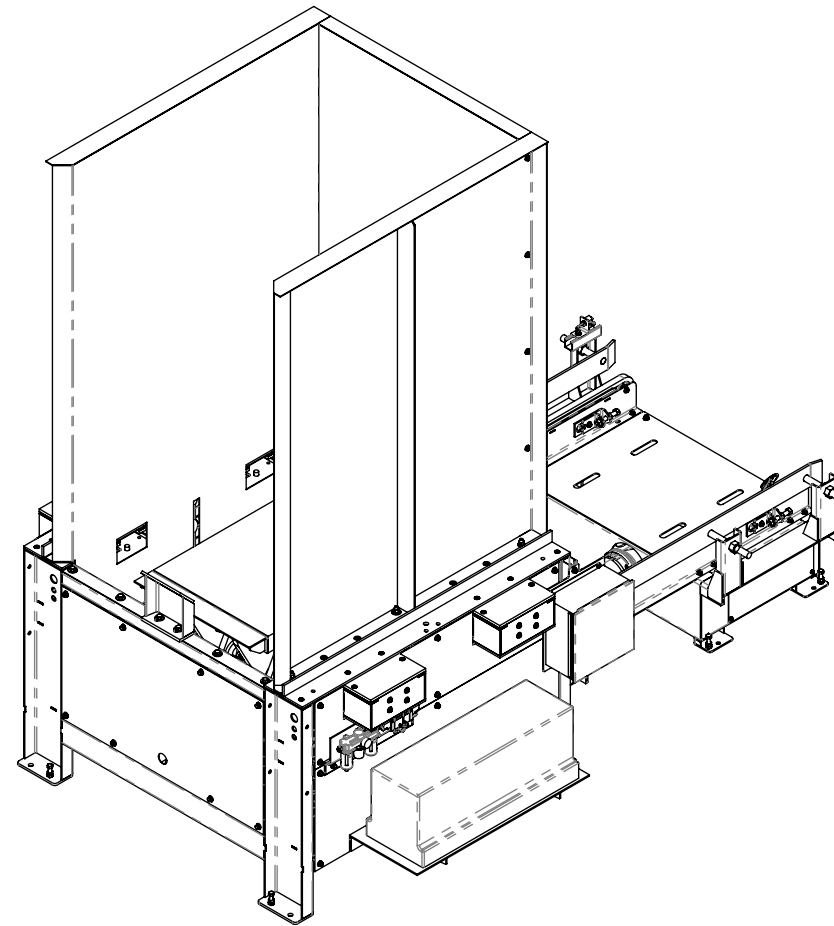

Model: PD-F-180

LOAD CAPACITY : 1500 LBS. MAXIMUM LOAD

MODEL: PD-F

DESCRIPTION: PALLET DISPENSER w/ MULTI-STRAND CHAIN CONVEYOR

PAGE: 1 of 2

LEWCO, INC. IS COMMITTED TO CONTINUOUS IMPROVEMENT AND RESERVES THE RIGHT TO CHANGE DESIGNS AND SPECIFICATIONS WITHOUT NOTICE.

THIS DRAWING MUST NOT BE COPIED, REPRODUCED OR USED FOR ANY PURPOSE WITHOUT THE WRITTEN CONSENT OF LEWCO, INC. ALL RIGHTS RESERVED.

**LEWCO**

706 LANE ST. SANDUSKY, OH 44870, U.S.A.