

MODEL: PP90
DESCRIPTION: TURNTABLE w/ 90° ROTATION, PNEUMATICALLY OPERATED

TURNTABLE CAPACITY: 4000 LBS MAXIMUM LOAD EVENLY DISTRIBUTED	
LEWCO, INC. IS COMMITTED TO CONTINUOUS IMPROVEMENT AND RESERVES THE RIGHT TO CHANGE DESIGNS AND SPECIFICATIONS WITHOUT NOTICE.	
THIS DRAWING MUST NOT BE COPIED, REPRODUCED OR USED FOR ANY PURPOSE WITHOUT THE WRITTEN CONSENT OF LEWCO, INC. ALL RIGHTS RESERVED.	 706 LANE ST. SANDUSKY, OH 44870, U.S.A.

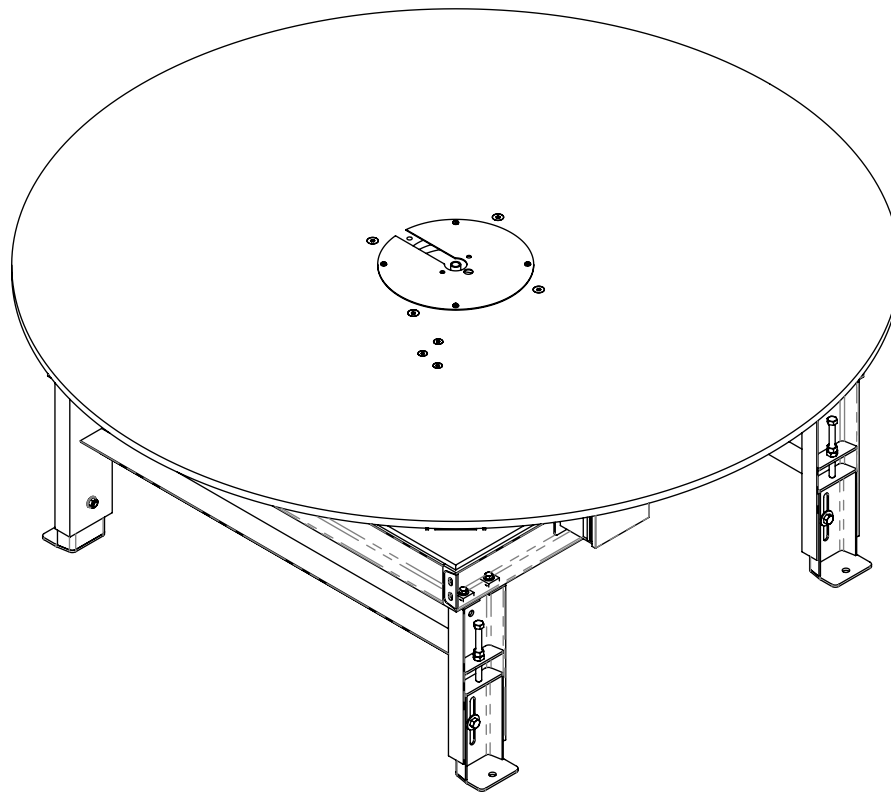

STRUCTURAL CHANNEL
 JACK-BOLT SUPPORTS FOR
 ELEVATION 19" AND TALLER

STANDARD SUPPORTS

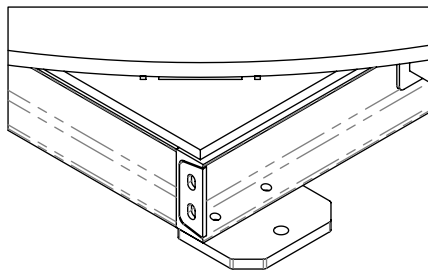

FLOOR PADS FOR
 LOW ELEVATIONS

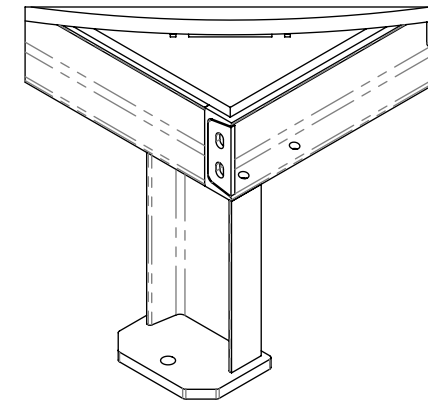

STRUCTURAL CHANNEL WELDED RISERS
 FOR ELEVATION UP TO 19"
 (JACK-BOLT SUPPORTS FOR TALLER ELEVATIONS)

MODEL: PP90

DESCRIPTION: TURNTABLE w/90° ROTATION, PNEUMATICALLY OPERATED

LEWCO, INC. IS COMMITTED TO CONTINUOUS
 IMPROVEMENT AND RESERVES THE RIGHT TO CHANGE
 DESIGNS AND SPECIFICATIONS WITHOUT NOTICE.

THIS DRAWING MUST NOT BE COPIED, REPRODUCED
 OR USED FOR ANY PURPOSE WITHOUT THE WRITTEN
 CONSENT OF LEWCO, INC. ALL RIGHTS RESERVED.



706 LANE ST. SANDUSKY, OH 44870, U.S.A.