

NOTE: Capacities are based on an evenly distributed load with a support every 5FT. Maximum total live load at 30 feet per minute (FPM) with 1-1/2 HP motor is 10,400 lbs. Maximum product weight to be conveyed is 2,500 lbs. total; not to exceed 1,000 lbs. per foot.

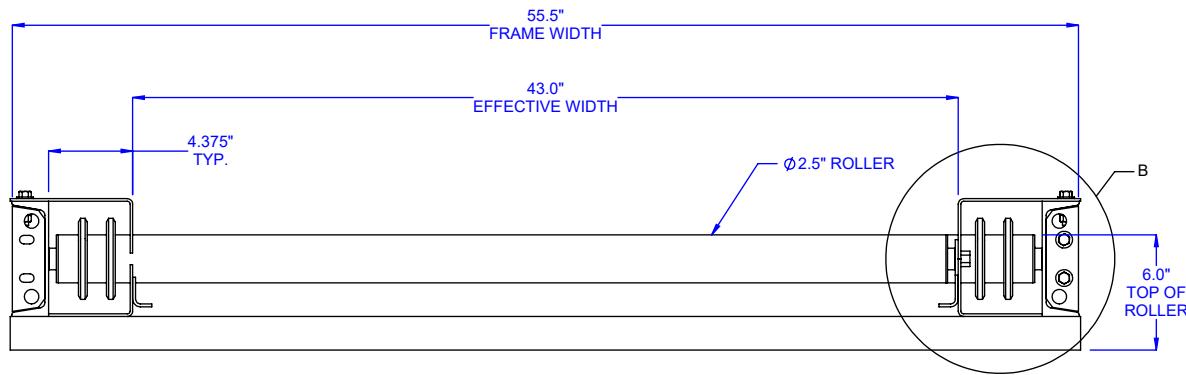

VIEW A-A

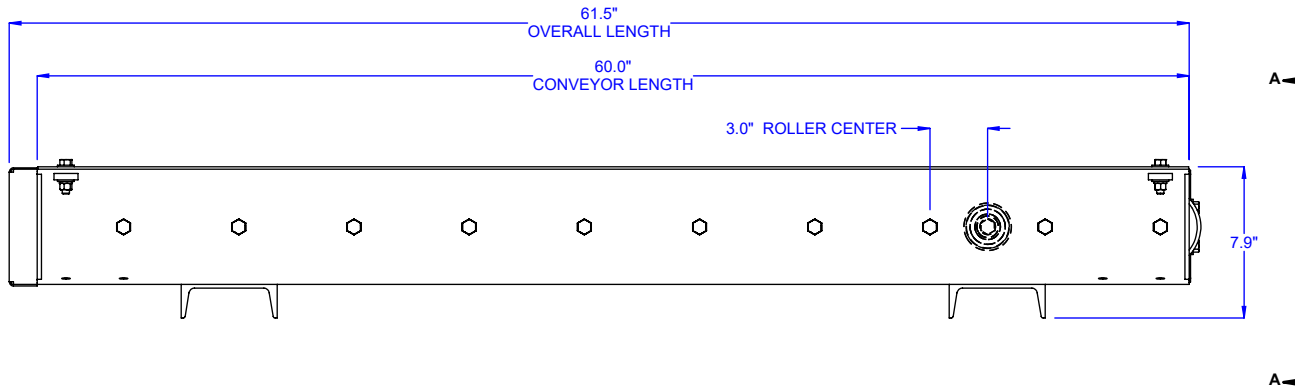
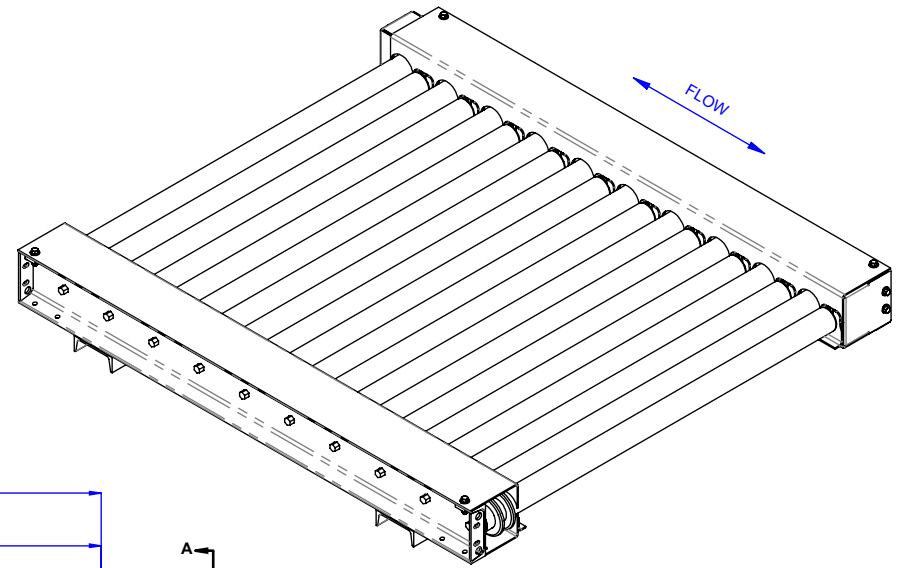
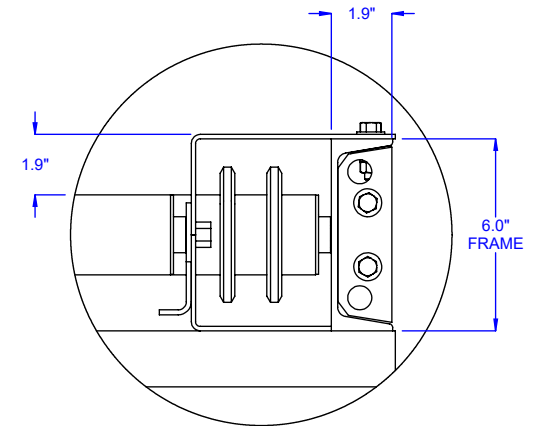

DETAIL B

MODEL: CDDB25-43-3-60-00-D99-F17-M98-A63-V98
DESCRIPTION: CDDB25, CHAIN DRIVEN ROLLER, DUAL CHAIN BOX

LEWCO, INC. IS COMMITTED TO CONTINUOUS IMPROVEMENT AND RESERVES THE RIGHT TO CHANGE DESIGNS AND SPECIFICATIONS WITHOUT NOTICE.

THIS DRAWING MUST NOT BE COPIED, REPRODUCED OR USED FOR ANY PURPOSE WITHOUT THE WRITTEN CONSENT OF LEWCO, INC. ALL RIGHTS RESERVED.



706 LANE ST. SANDUSKY, OH 44870, U.S.A.

OPTIONS

NOTE: Extension conveyors should be added equally on each end of the drive conveyor. Maximum overall conveyor length is limited to 50FT. with 3" roller centers.

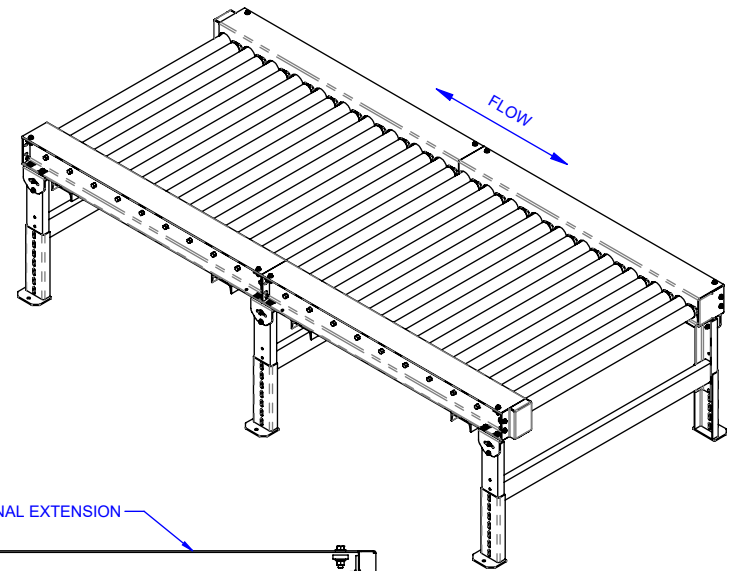

OPTIONAL SUPPORTS & EXTENSION SHOWN

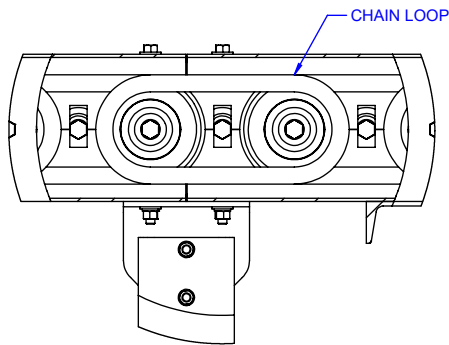
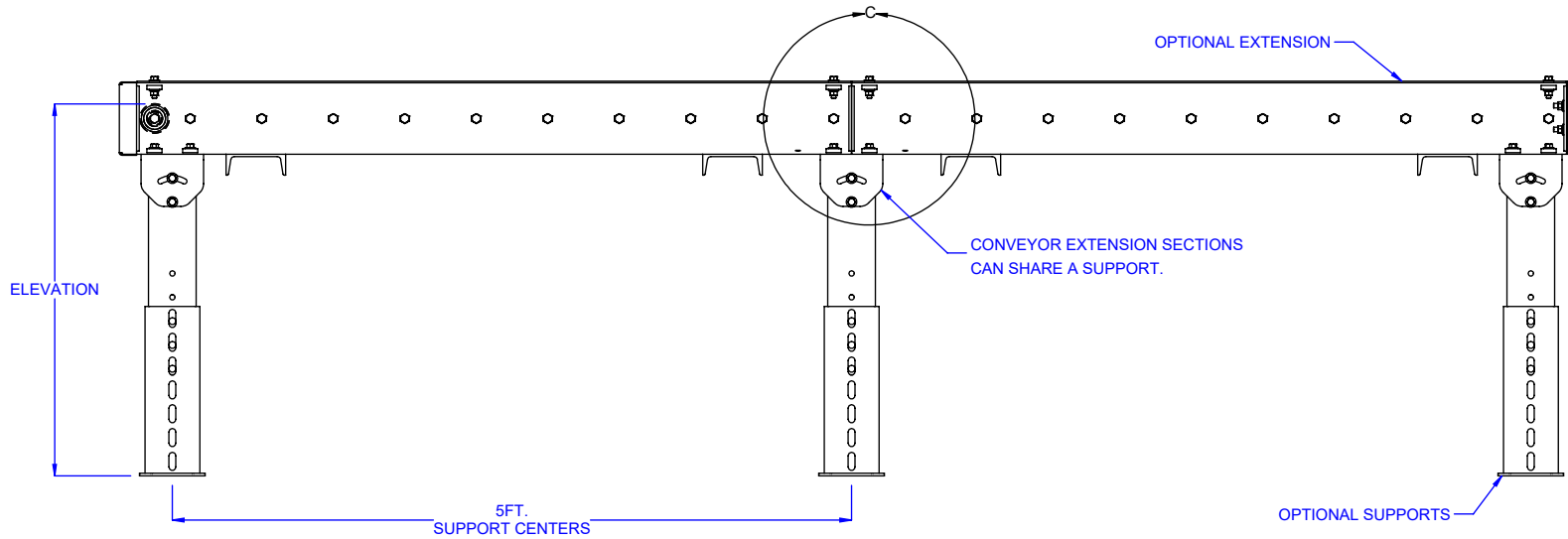

DETAIL C

MODEL: Cddb25
DESCRIPTION: Cddb25, CHAIN DRIVEN ROLLER, DUAL CHAIN BOX

LEWCO, INC. IS COMMITTED TO CONTINUOUS IMPROVEMENT AND RESERVES THE RIGHT TO CHANGE DESIGNS AND SPECIFICATIONS WITHOUT NOTICE.

THIS DRAWING MUST NOT BE COPIED, REPRODUCED OR USED FOR ANY PURPOSE WITHOUT THE WRITTEN CONSENT OF LEWCO, INC. ALL RIGHTS RESERVED.



706 LANE ST. SANDUSKY, OH 44870, U.S.A.