

MDCSW – Medium Duty, Channel Frame Slider Bed, Wide Series

Model MDCSW is a medium duty, channel frame slider bed belt conveyor designed for wide applications. The channel frame style makes it ideal for mounting sensors and other devices. These conveyors are used to provide a reliable way of transporting products in assembly, sorting, testing, and packaging applications.

Belt Width

- 54", 60", 66", 72"

Length

- 60" to 1,200"

Belt

- PVC120 EMB embossed cover with clipper lacing.
- Optional:
 - PVC120 smooth top
 - PVC150 rough top
 - PVC120, Black, friction both sides
 - PVC Food grade, White
 - Thermoplastic polyurethane (TPU) Covered Belt
 - PVC longitudinal groove
 - No Belt
- V-Guided Belt design also available.

Drive Location

- End Drive, Bottom Right
- Optional:
 - End Drive, Bottom, Left
 - End Drive, Side, Right or Left
 - Center Drive, Right or Left (standard for conveyors with reverse)

Motor

- 3/4 HP to 2 HP
- Totally Enclosed Fan Cooled motor
- Optional:
 - Inverter Duty motor
 - Power Off Brake motor
- Voltage: 230/460/ 3Ph/ 60hz
- Optional:
 - 115V/ 1Ph/ 60Hz
 - 208V/ 1Ph/ 60Hz
 - 230V/ 1Ph/ 60Hz
 - 575V/ 3Ph/ 60Hz
 - 90V DC

Speed

- 15 to 300 FPM (feet per minute)
- Reverse capability optional

Control Options

- No controls (provided by others)
- Variable Speed Controller
- Combination motor starter with disconnect, fixed speed
- Combination motor starter with disconnect, variable speed
- PLC with HMI

Conveyor Color

- Blue (RAL 5017)
- Guards are yellow (RAL 1023)
- Moving parts are bright red orange (RAL 2008).
- Optional:
 - Light Gray (RAL 7035)
 - Repose Gray (not an RAL)
 - Patina Green (RAL 6000)
 - Signal White (RAL 9003)
 - Jet Black (RAL 9005)
 - Flat Black (not an RAL)
 - Custom colors available

Additional Options

- Conveyor Supports with or without casters
- Guardrail
- Photo Eye Sensor(s)
- Custom sizes and features available. Please consult a LEWCO Applications Engineer for more information.

Quality Assurance

- Each unit comes complete with a (1) year warranty.
- Manufactured under ISO 9001 Quality Certified System.

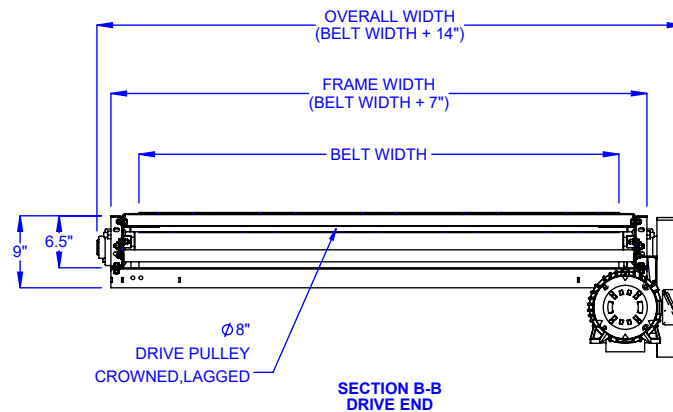
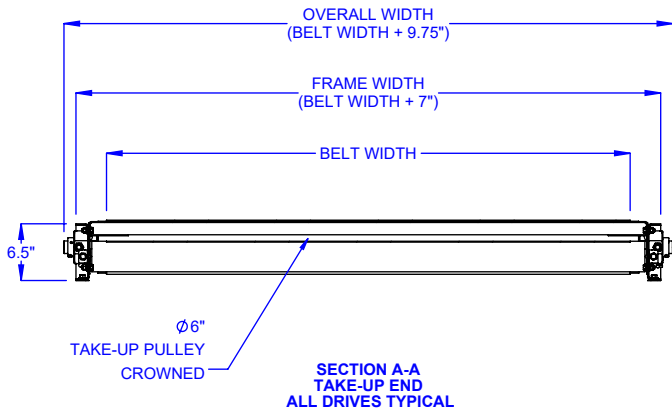
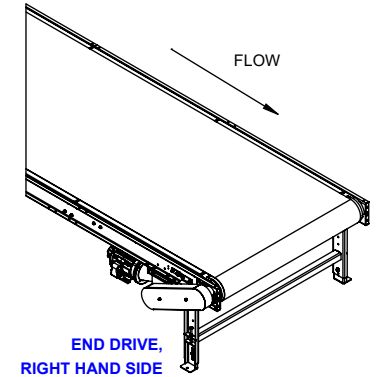
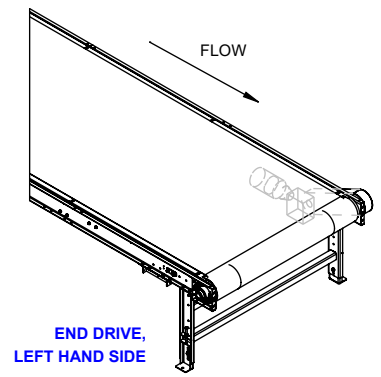
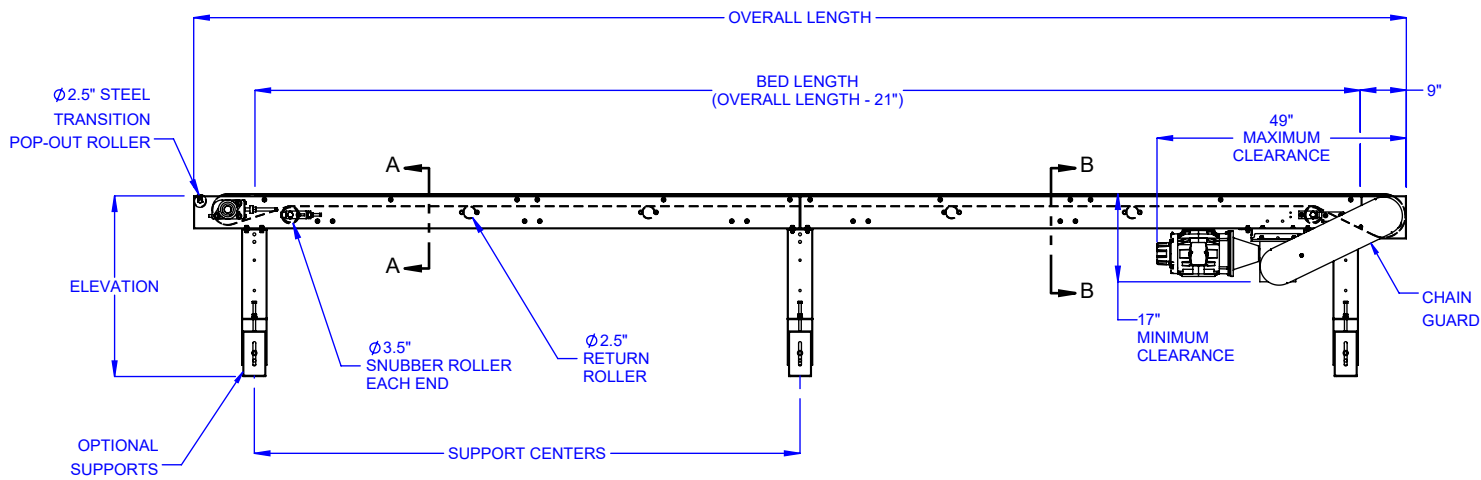

LOAD CAPACITY @ 60 FPM (LBS)				
HP	WIDTH			
	54"	60"	66"	72"
1/2	245	240	235	225
3/4	400	395	385	380
1	550	545	540	530
1 1/2	860	850	845	840
2	1165	1155	1150	1145
LOAD CAPACITY @ 30 FPM (LBS)				
HP	WIDTH			
	54"	60"	66"	72"
1/2	555	550	540	535
3/4	860	855	850	840
1	1165	1160	1155	1145
1 1/2	1780	1770	1765	1760
2	2390	2385	2380	2370

MAXIMUM LOAD PER LINEAR FOOT OF CONVEYOR IS 100 POUNDS - NOT TO EXCEED CAPACITY ABOVE

MODEL: MDCSW
DESCRIPTION: MEDIUM DUTY CHANNEL SLIDER BED WIDE BELT CONVEYOR

LEWCO, INC. IS COMMITTED TO CONTINUOUS IMPROVEMENT AND RESERVES THE RIGHT TO CHANGE DESIGNS AND SPECIFICATIONS WITHOUT NOTICE.

THIS DRAWING MUST NOT BE COPIED, REPRODUCED OR USED FOR ANY PURPOSE WITHOUT THE WRITTEN CONSENT OF LEWCO, INC. ALL RIGHTS RESERVED.



706 LANE ST. SANDUSKY, OH 44870, U.S.A.

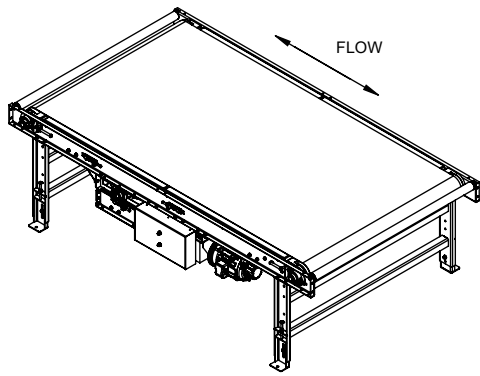

CENTER DRIVE,RIGHT HAND

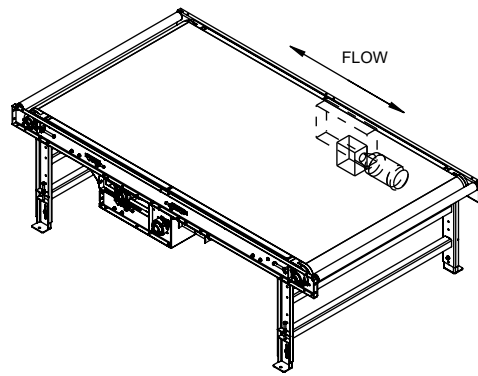

CENTER DRIVE,LEFT HAND

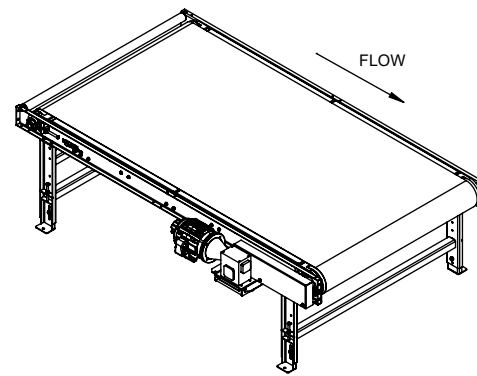

SIDE DRIVE,RIGHT HAND

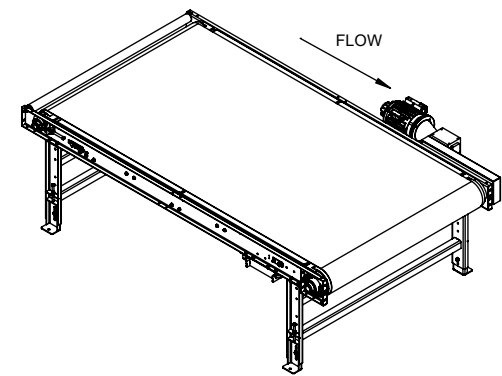

SIDE DRIVE,LEFT HAND

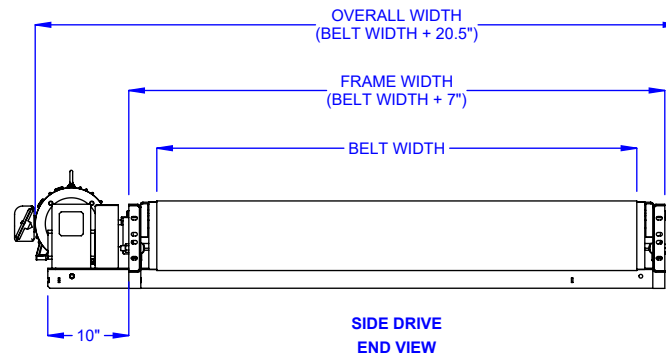
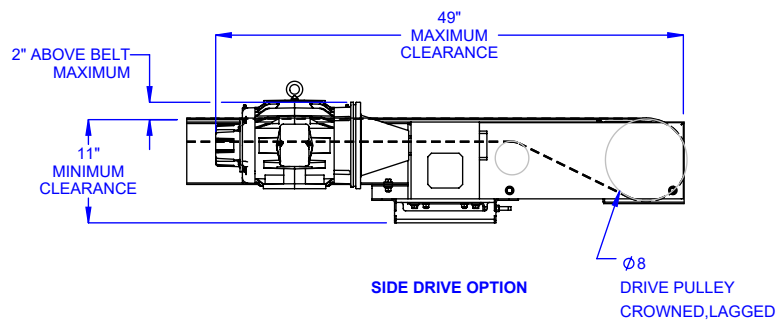
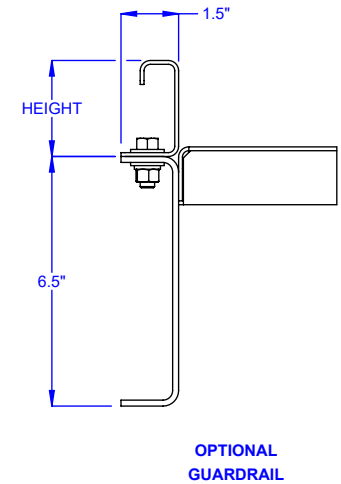
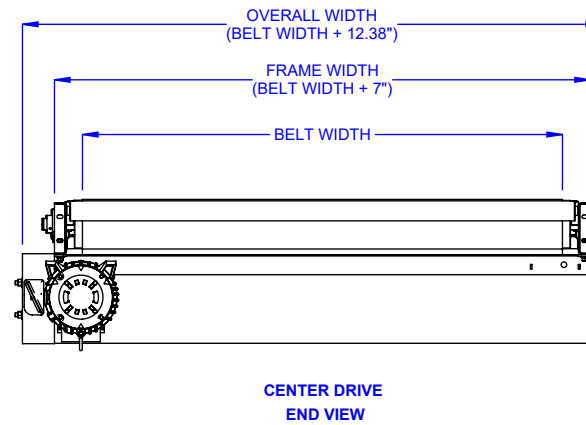
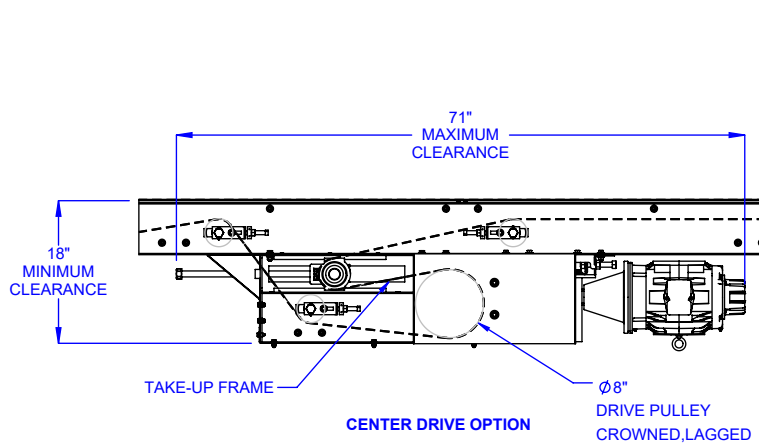

MODEL: MDCSW

DESCRIPTION: MEDIUM DUTY CHANNEL SLIDER BED WIDE BELT CONVEYOR

LEWCO, INC. IS COMMITTED TO CONTINUOUS IMPROVEMENT AND RESERVES THE RIGHT TO CHANGE DESIGNS AND SPECIFICATIONS WITHOUT NOTICE.

THIS DRAWING MUST NOT BE COPIED, REPRODUCED OR USED FOR ANY PURPOSE WITHOUT THE WRITTEN CONSENT OF LEWCO, INC. ALL RIGHTS RESERVED.



706 LANE ST. SANDUSKY, OH 44870, U.S.A.

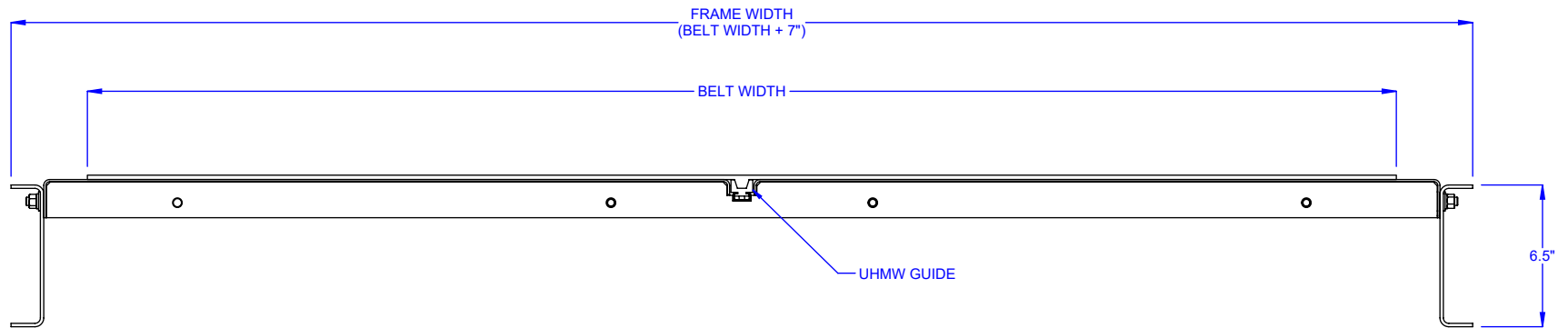

OPTIONAL V-GUIDED CONSTRUCTION
 (NOTE : PULLEYS ARE GROOVED TO ACCOMMODATE THE V-BELT)

MODEL: MDCSW

DESCRIPTION: MEDIUM DUTY CHANNEL SLIDER BED WIDE BELT CONVEYOR

LEWCO, INC. IS COMMITTED TO CONTINUOUS IMPROVEMENT AND RESERVES THE RIGHT TO CHANGE DESIGNS AND SPECIFICATIONS WITHOUT NOTICE.

THIS DRAWING MUST NOT BE COPIED, REPRODUCED OR USED FOR ANY PURPOSE WITHOUT THE WRITTEN CONSENT OF LEWCO, INC. ALL RIGHTS RESERVED.



706 LANE ST. SANDUSKY, OH 44870, U.S.A.