



Model: CDLR25

Chain Driven Live Roller Conveyor, 2.5" dia.

Chain driven roller conveyor is the workhorse of heavy-duty material handling and is an excellent choice for moving pallets, tires, drums, structural steel, and other heavy loads. Its rugged welded frame construction can withstand the most abusive of environments. Chain driven roller conveyor also provides versatility in production lines because it can easily incorporate with chain transfers, turntables, and curves.

Effective Width

- 6" to 64"

Length

- 36" to 600"

Roller Centers

- 4.5", 6", 9", or 12"
- For 3" see model CDDDB25

Rollers

- 2.50" dia. x 11ga. mild steel tube with 11/16" hex axle, spring retained, with precision, greased packed ABEC bearings, and #60 sprockets.
- Optional:
 - Cotter pin retained axle
 - Galvanized roller tube
 - Polyurethane roller sleeve
 - Ultrex accumulation sleeves

Frame Construction

- Structural channel, 6"x8.2# on chain box side & 4"x5.4# on opposite side with rollers set 1/4" high
- Optional:
 - Structural channel, 6"x8.2# with rollers set 1-3/4" low
 - Formed 8ga. channel, 6" on chain box side & 4" on opposite side with rollers set 1/4" high (bolted frame)
 - Formed 6"x8ga. channel with rollers set 1-3/4" low (bolted frame)

Drive Location

- Standard drive is mounted high near center of conveyor length on chain box side.
- Optional:
 - Drive mounted low or drive mounted below and within frame, near center.

Motor

- 1/2 HP to 2 HP
- Totally Enclosed Fan Cooled motor
- Optional:
 - Inverter Duty motor
 - Power Off Brake motor
- Voltage: 230/460/ 3Ph/ 60hz
- Optional:
 - 115V/ 1Ph/ 60Hz
 - 208V/ 1Ph/ 60Hz
 - 230V/ 1Ph/ 60Hz
 - 575V/ 3Ph/ 60Hz
 - 24VDC

Speed

- 10 to 150 FPM (feet per minute)

Control Options

- Variable Speed Controller
- Combination motor starter with disconnect, fixed speed
- Combination motor starter with disconnect, variable speed
- PLC with HMI
- No controls (provided by others)

Conveyor Color

- Blue (RAL 5017)
- Guards are yellow (RAL 1023)
- Moving parts are bright red orange (RAL 2008).
- Optional:
 - Light Gray (RAL 7035)
 - Repose Gray (not an RAL)
 - Patina Green (RAL 6000)
 - Signal White (RAL 9003)
 - Jet Black (RAL 9005)
 - Flat Black (not an RAL)
 - Custom colors available

Additional Options

- Conveyor Supports
- Guardrail
- Fork Truck Barriers
- Photo Eye Sensor(s)
- Custom sizes and features available. Please consult a LEWCO Applications Engineer for more information.

Quality Assurance

- Each unit comes complete with a (1) year warranty and is tested prior to shipment.
- Manufactured under ISO 9001 Quality Certified System.

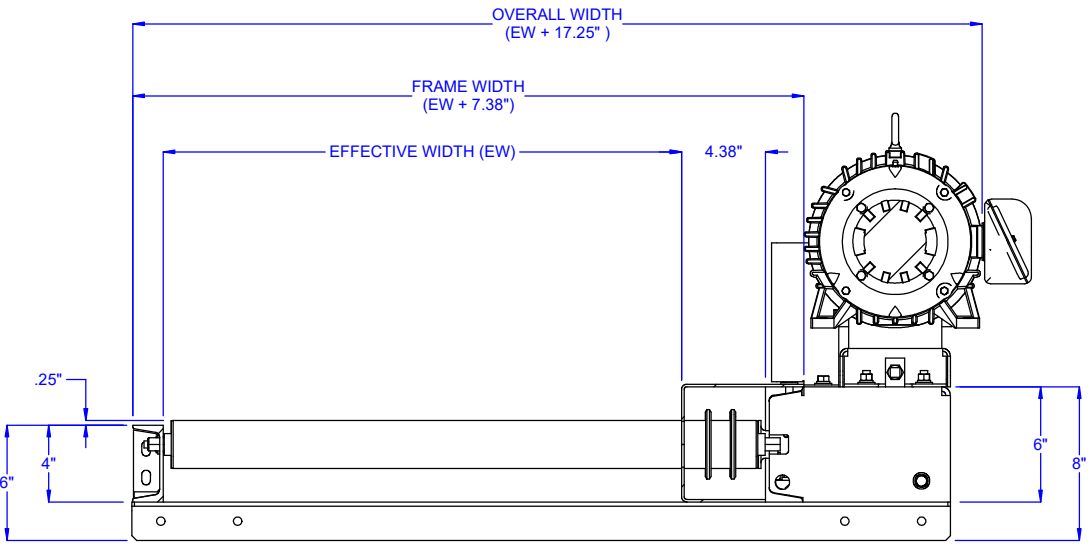
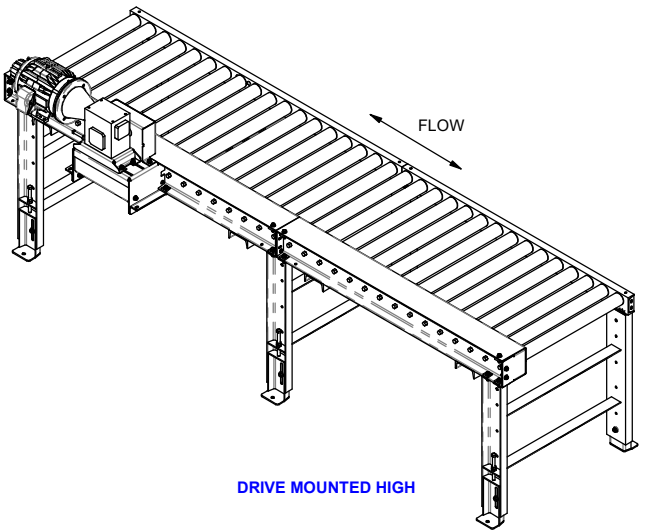
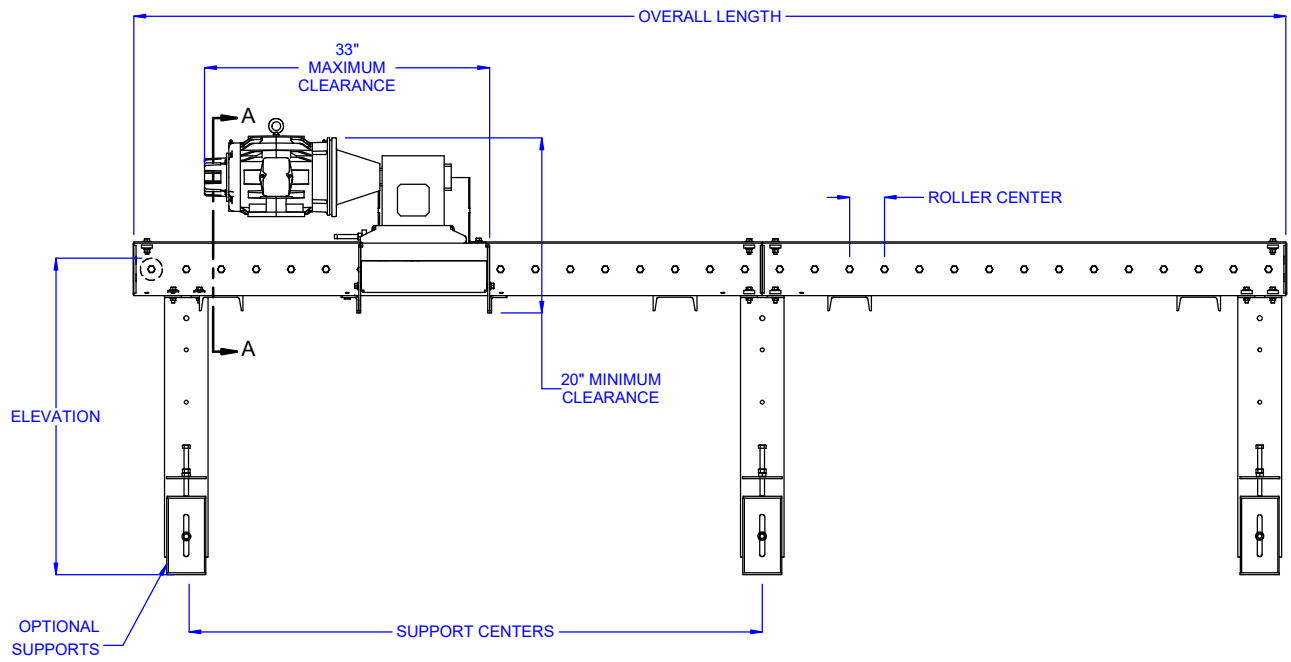

SECTION A-A
 DRIVE MOUNTED HIGH
 STANDARD FRAME
 STRUCTURAL CHANNEL, 6" x 8.2# & 4" x 6.4#

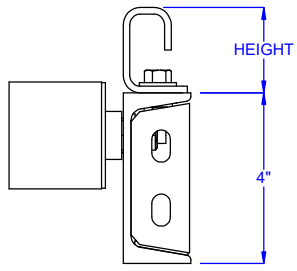

OPTIONAL
 GUARDRAIL

LOAD CAPACITY (LBS) @ 60 FPM 4.5" or 6" ROLLER CENTERS			
HP	WIDTH		
	12"	36"	60"
1/2	1550	1300	1050
3/4	2500	2250	2000
1	4100	3850	3600
1 1/2	6300	6050	5850
2	10300	10100	9850
LOAD CAPACITY (LBS) @ 30 FPM 4.5" or 6" ROLLER CENTERS			
HP	WIDTH		
	12"	36"	60"
1/2	4150	3900	3650
3/4	6350	6100	5850
1	10350	10100	9850
1 1/2	15650	15450	15200
2	20000	20000	20000
MAXIMUM UNIT LOAD PER LINEAR FOOT OF CONVEYOR IS 1000 LBS - NOT TO EXCEED CAPACITY ABOVE			

* Based on 20 FT. Note: HP requirements will vary for different drive options, conveyor lengths, roller centers, pallet types and chain lubrication conditions. Consult factory.

MODEL: CDLR25

DESCRIPTION: CHAIN DRIVEN LIVE ROLLER CONVEYOR

LEWCO, INC. IS COMMITTED TO CONTINUOUS IMPROVEMENT AND RESERVES THE RIGHT TO CHANGE DESIGNS AND SPECIFICATIONS WITHOUT NOTICE.

THIS DRAWING MUST NOT BE COPIED, REPRODUCED OR USED FOR ANY PURPOSE WITHOUT THE WRITTEN CONSENT OF LEWCO, INC. ALL RIGHTS RESERVED.



706 LANE ST. SANDUSKY, OH 44870, U.S.A.

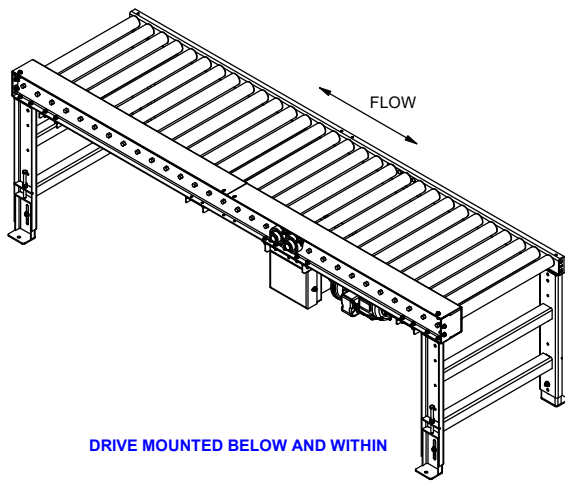

DRIVE MOUNTED BELOW AND WITHIN

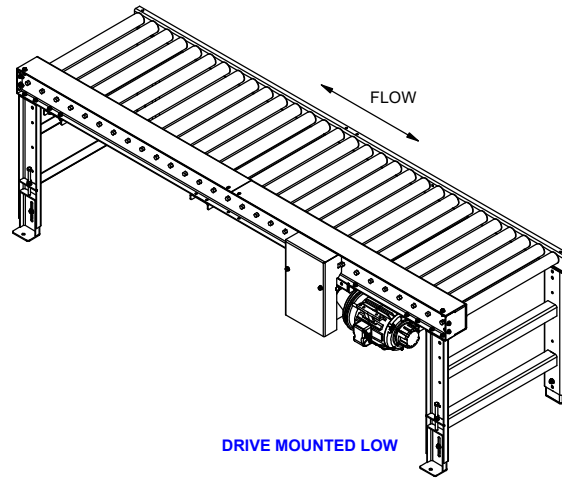

DRIVE MOUNTED LOW

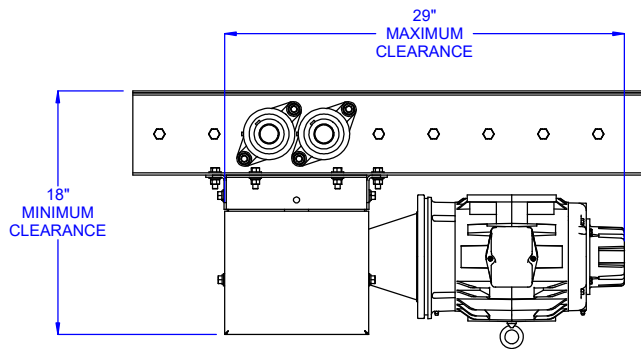

DRIVE MOUNTED
BELOW AND WITHIN
OPTION

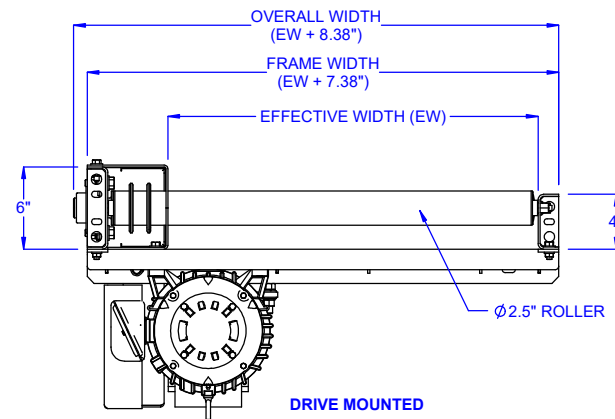

DRIVE MOUNTED
BELOW AND WITHIN
END VIEW

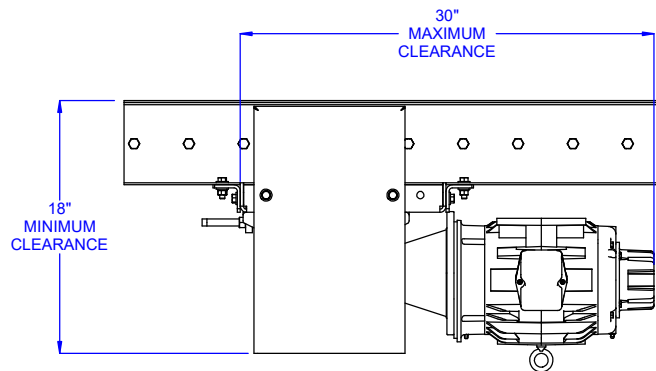

DRIVE MOUNTED LOW
OPTION

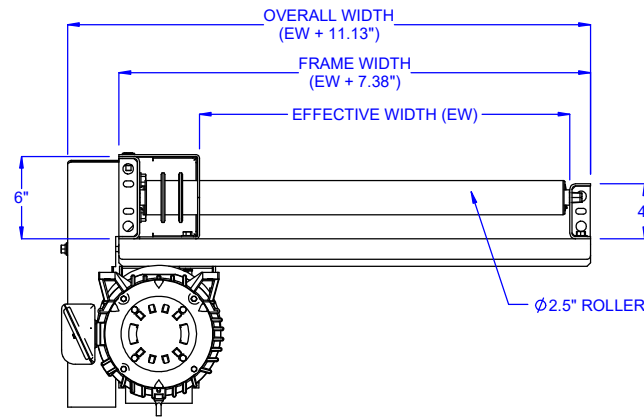

DRIVE MOUNTED LOW
END VIEW

MODEL: CDLR25

DESCRIPTION: CHAIN DRIVEN LIVE ROLLER CONVEYOR

LEWCO, INC. IS COMMITTED TO CONTINUOUS IMPROVEMENT AND RESERVES THE RIGHT TO CHANGE DESIGNS AND SPECIFICATIONS WITHOUT NOTICE.

THIS DRAWING MUST NOT BE COPIED, REPRODUCED OR USED FOR ANY PURPOSE WITHOUT THE WRITTEN CONSENT OF LEWCO, INC. ALL RIGHTS RESERVED.



706 LANE ST. SANDUSKY, OH 44870, U.S.A.

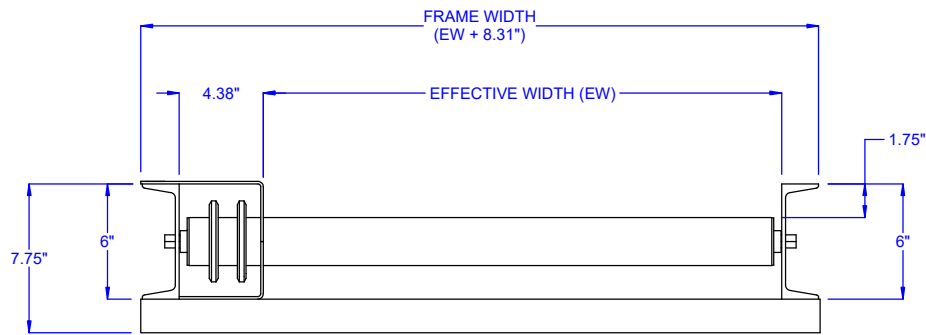

OPTIONAL FRAME
STRUCTURAL CHANNEL, 6" x 8.2#

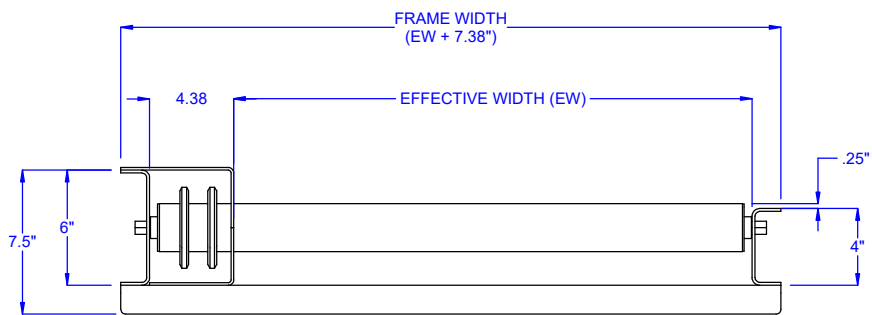

OPTIONAL FRAME
FORMED 8 GA. CHANNEL, 6" x 1-1/2" & 4"x 1-1/2"

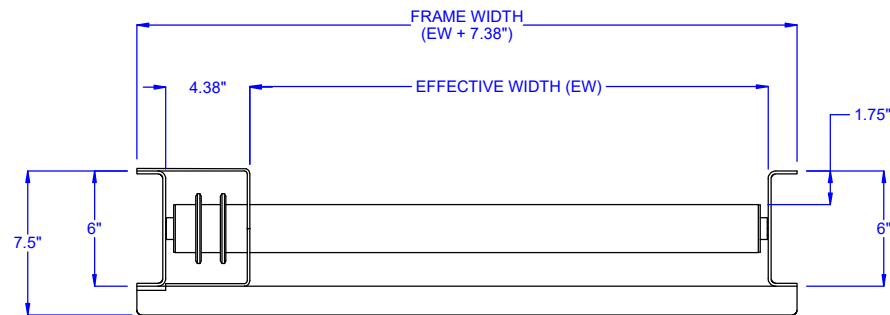

OPTIONAL FRAME
FORMED 8 GA. CHANNEL, 6" x 1-1/2"

MODEL: CDLR25

DESCRIPTION: CHAIN DRIVEN LIVE ROLLER CONVEYOR

LEWCO, INC. IS COMMITTED TO CONTINUOUS
IMPROVEMENT AND RESERVES THE RIGHT TO CHANGE
DESIGNS AND SPECIFICATIONS WITHOUT NOTICE.

THIS DRAWING MUST NOT BE COPIED, REPRODUCED
OR USED FOR ANY PURPOSE WITHOUT THE WRITTEN
CONSENT OF LEWCO, INC. ALL RIGHTS RESERVED.

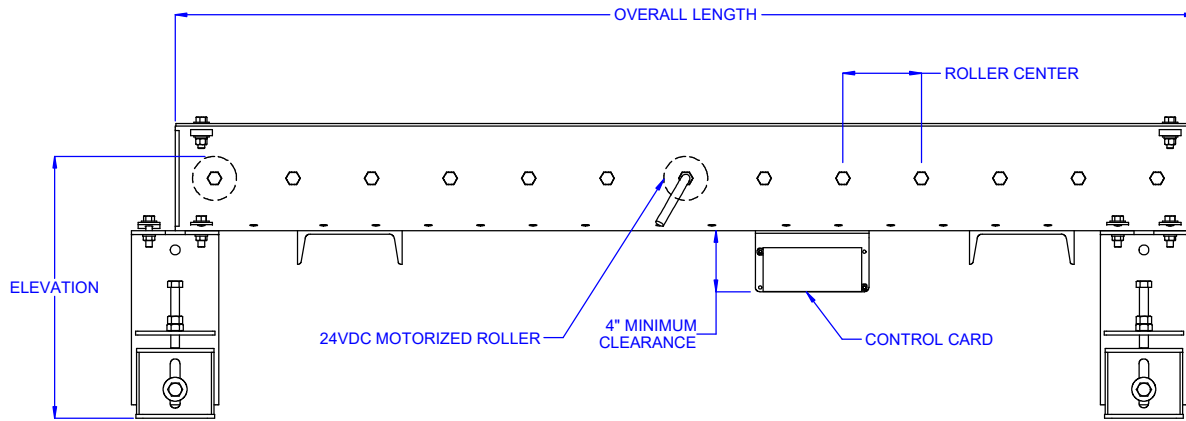
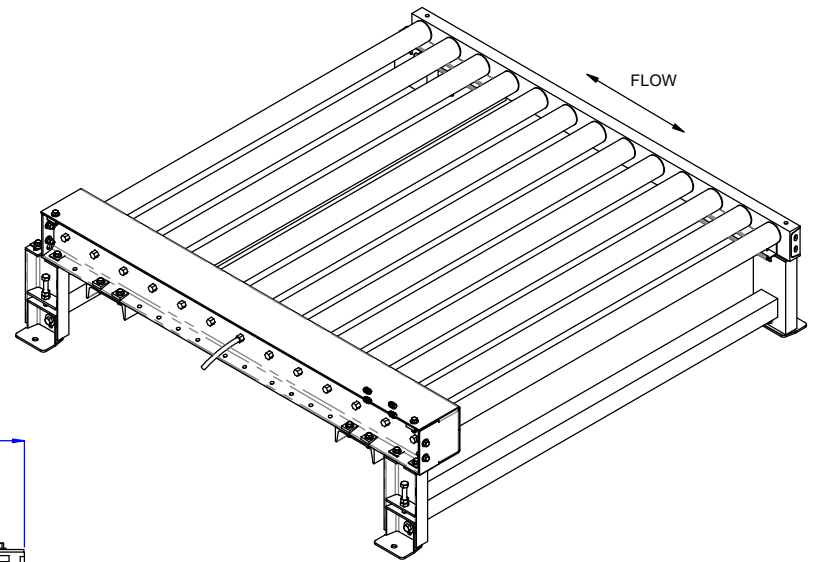

24VDC OPTION

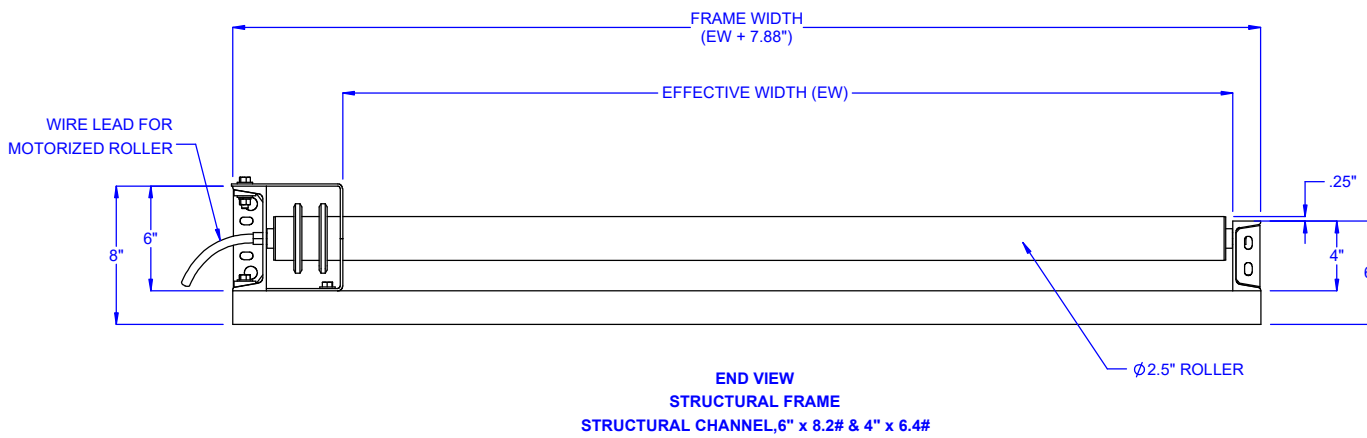

24VDC CONVEYOR NOTES:
MOTORIZED ROLLER SHOULD NOT DRIVE MORE THAN (8) NON-POWERED ROLLERS ON EITHER SIDE

MODEL: CDLR25
DESCRIPTION: CHAIN DRIVEN LIVE ROLLER CONVEYOR

LEWCO, INC. IS COMMITTED TO CONTINUOUS IMPROVEMENT AND RESERVES THE RIGHT TO CHANGE DESIGNS AND SPECIFICATIONS WITHOUT NOTICE.

THIS DRAWING MUST NOT BE COPIED, REPRODUCED OR USED FOR ANY PURPOSE WITHOUT THE WRITTEN CONSENT OF LEWCO, INC. ALL RIGHTS RESERVED.



706 LANE ST. SANDUSKY, OH 44870, U.S.A.