

Model: CDDB25

Chain Driven Roller, Dual Chain Box, 2.5" dia.

Chain driven roller conveyor is the workhorse of heavy-duty material handling and is an excellent choice for moving pallets, tires, drums, structural steel, and other heavy loads. Its rugged welded frame construction can withstand the most abusive of environments. Chain driven roller conveyor also provides versatility in production lines because it can easily incorporate with chain transfers, turntables, and curves.

Effective Width

- 12" to 60"

Length

- 48" to 600"

Roller Centers

- 3"
- For other spacing see CDLR25

Rollers

- 2.50" dia. X 11ga. mild steel tube with 11/16" hex axle, spring retained, with precision, greased packed ABEC bearings, and #60 sprockets.
- Optional:
 - Galvanized roller tube
 - Polyurethane roller sleeve
 - Ultrex accumulation sleeves

Frame Construction

- Structural channel, 6"x8.2# with rollers set 1-3/4" low
- Optional:
 - Formed 6"x8ga. channel with rollers set 1-3/4" low (bolted frame)

Drive Location

- Standard drive is mounted high near center of conveyor length on chain box side.
- Optional:
 - Drive mounted low near center

Motor

- 1/2 HP to 2 HP
- Totally Enclosed Fan Cooled motor
- Optional:
 - Inverter Duty motor
 - Power Off Brake motor
- Voltage: 230/460/ 3Ph/ 60hz
- Optional:
 - 115V/ 1Ph/ 60Hz
 - 208V/ 1Ph/ 60Hz
 - 230V/ 1Ph/ 60Hz
 - 575V/ 3Ph/ 60Hz
 - 24VDC

Speed

- 10 to 150 FPM (feet per minute)

Control Options

- Variable Speed Controller
- Combination motor starter with disconnect, fixed speed
- Combination motor starter with disconnect, variable speed
- PLC with HMI
- No controls (provided by others)

Conveyor Color

- Blue (RAL 5017)
- Guards are yellow (RAL 1023)
- Moving parts are bright red orange (RAL 2008).
- Optional:
 - Light Gray (RAL 7035)
 - Repose Gray (not an RAL)
 - Patina Green (RAL 6000)
 - Signal White (RAL 9003)
 - Jet Black (RAL 9005)
 - Flat Black (not an RAL)
 - Custom colors available

Additional Options

- Conveyor Supports
- Guardrail
- Fork Truck Barriers
- Photo Eye Sensor(s)
- Custom sizes and features available. Please consult a LEWCO Applications Engineer for more information.

Quality Assurance

- Each unit comes complete with a (1) year warranty and is tested prior to shipment.
- Manufactured under ISO 9001 Quality Certified System.

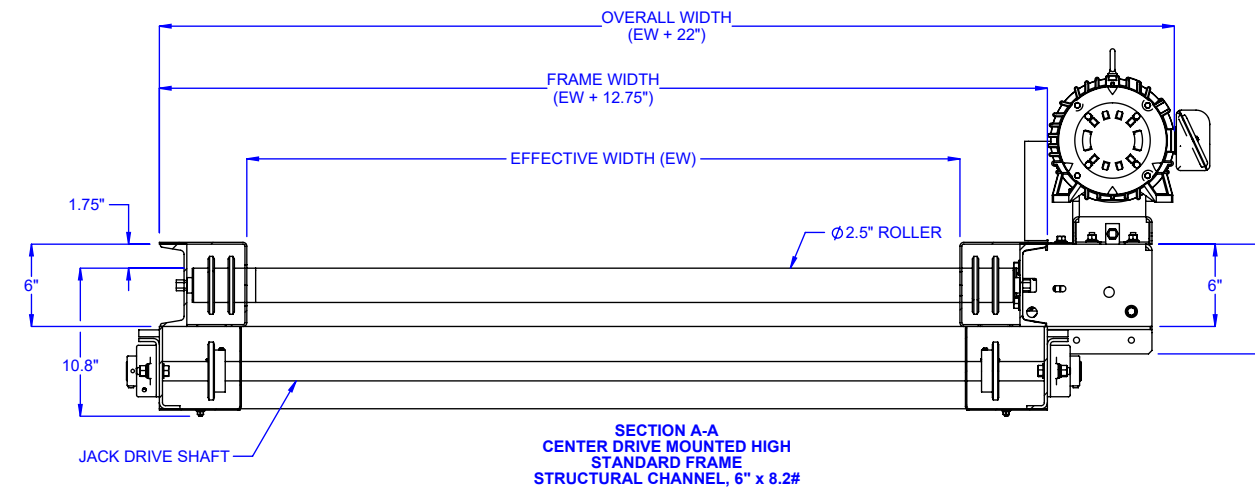
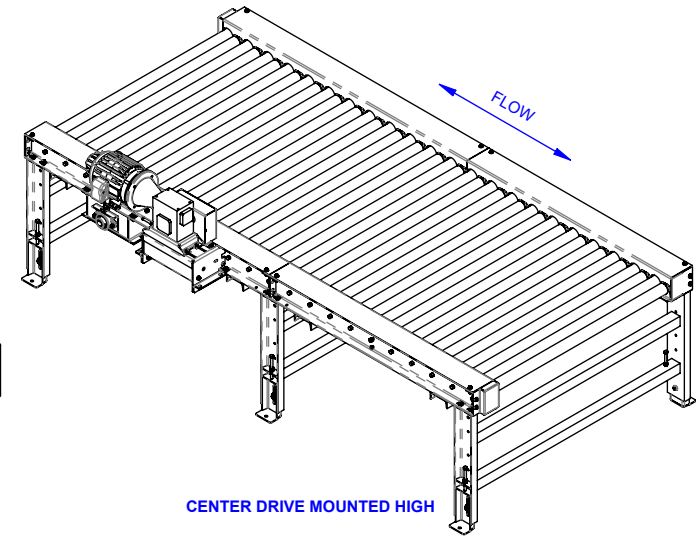
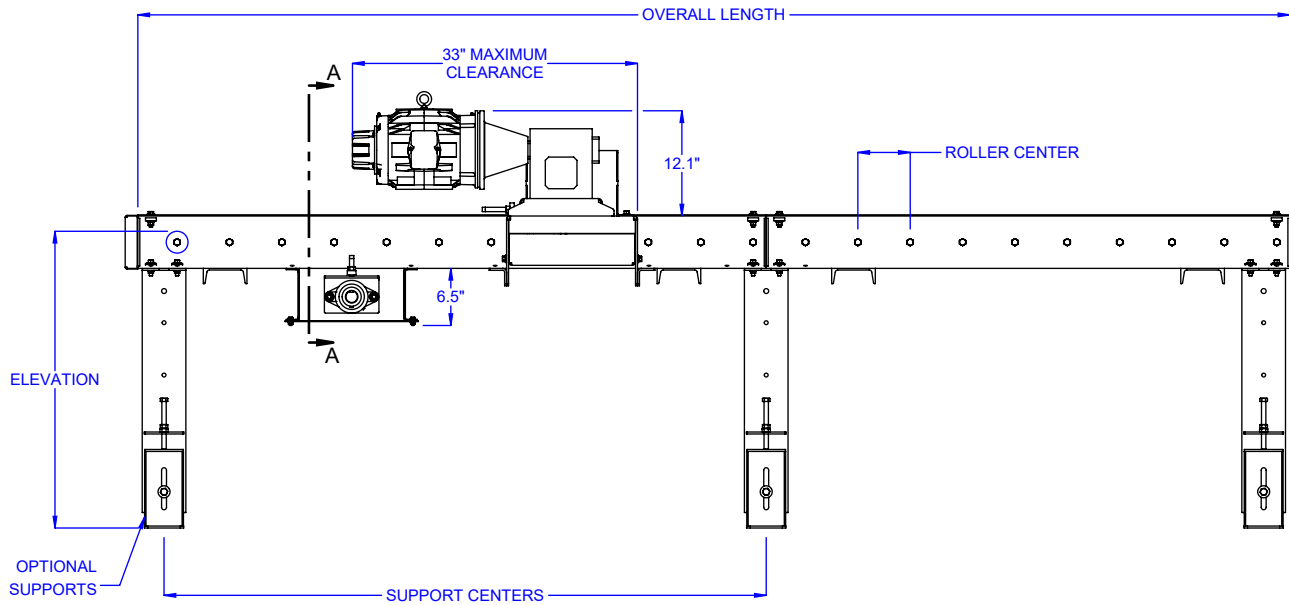

LOAD CAPACITY @ 60 FPM (LBS) 3" ROLLER CENTERS, 20 FT LENGTH			
HP	WIDTH		
	12"	36"	60"
1/2	700	200	-
3/4	1900	1450	350
1	2800	2300	1800
1 1/2	4500	4000	3500
2	6200	5700	5250

LOAD CAPACITY @ 30 FPM (LBS) 3" ROLLER CENTERS, 20 FT LENGTH			
HP	WIDTH		
	12"	36"	60"
1/2	2750	2300	1800
3/4	4500	4000	3550
1	6200	5750	5250
1 1/2	11350	10900	10400
2	18600	18100	17600

MAXIMUM LOAD PER LINEAR FOOT OF CONVEYOR IS 1000 - NOT TO EXCEED CAPACITY ABOVE

* HP requirements will vary for different drive options and conveyor lengths, roller centers, pallet types and chain lubrication conditions. Consult factory.

MODEL: CDDB25
 DESCRIPTION: CHAIN DRIVEN LIVE ROLLER CONVEYOR, DUAL CHAIN BOX

LEWCO, INC. IS COMMITTED TO CONTINUOUS IMPROVEMENT AND RESERVES THE RIGHT TO CHANGE DESIGNS AND SPECIFICATIONS WITHOUT NOTICE.

THIS DRAWING MUST NOT BE COPIED, REPRODUCED OR USED FOR ANY PURPOSE WITHOUT THE WRITTEN CONSENT OF LEWCO, INC. ALL RIGHTS RESERVED.

LEWCO
 706 LANE ST. SANDUSKY, OH 44870, U.S.A.

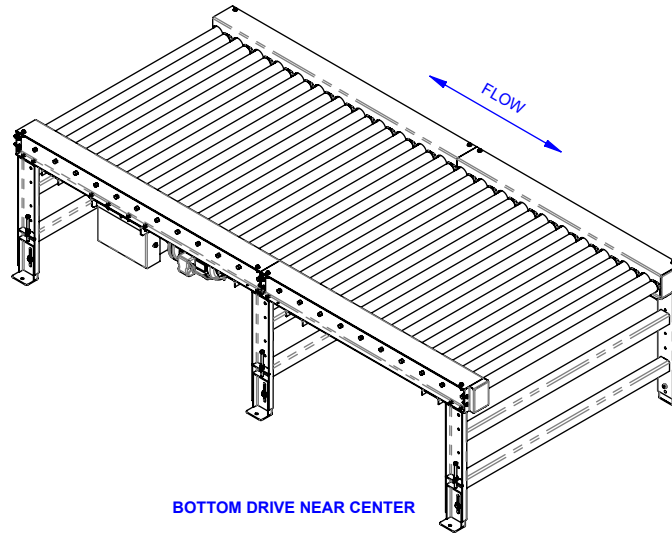

BOTTOM DRIVE NEAR CENTER

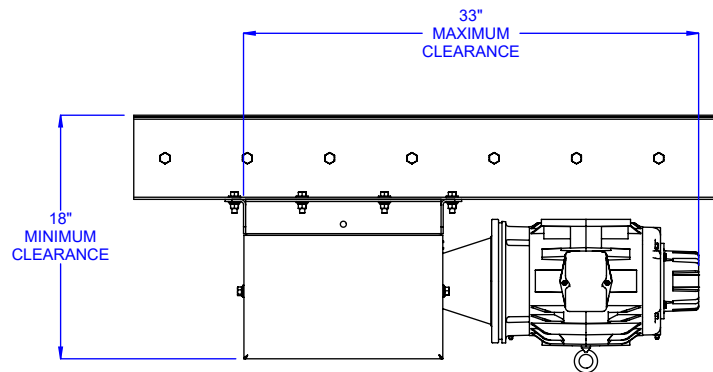

**BOTTOM DRIVE
NEAR CENTER
OPTION**

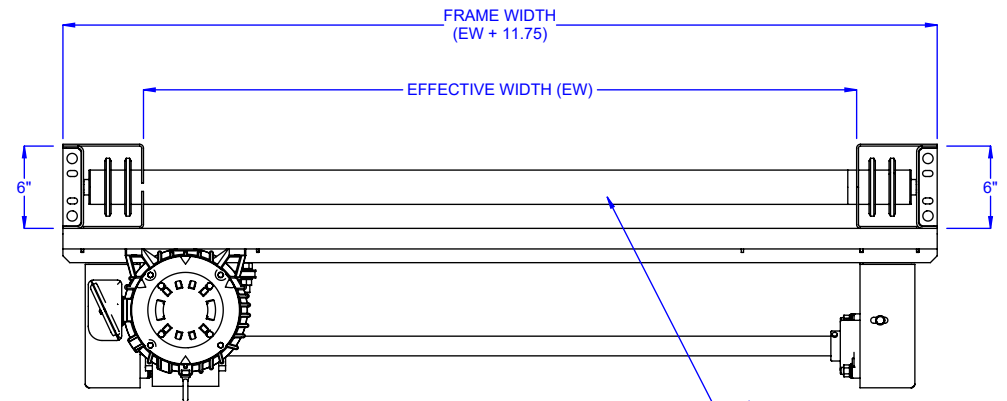

**BOTTOM DRIVE
NEAR CENTER
END VIEW**

Ø2.5" ROLLER

MODEL: CDDB25
DESCRIPTION: CHAIN DRIVEN LIVE ROLLER CONVEYOR, DUAL CHAIN BOX

LEWCO, INC. IS COMMITTED TO CONTINUOUS IMPROVEMENT AND RESERVES THE RIGHT TO CHANGE DESIGNS AND SPECIFICATIONS WITHOUT NOTICE.

THIS DRAWING MUST NOT BE COPIED, REPRODUCED OR USED FOR ANY PURPOSE WITHOUT THE WRITTEN CONSENT OF LEWCO, INC. ALL RIGHTS RESERVED.

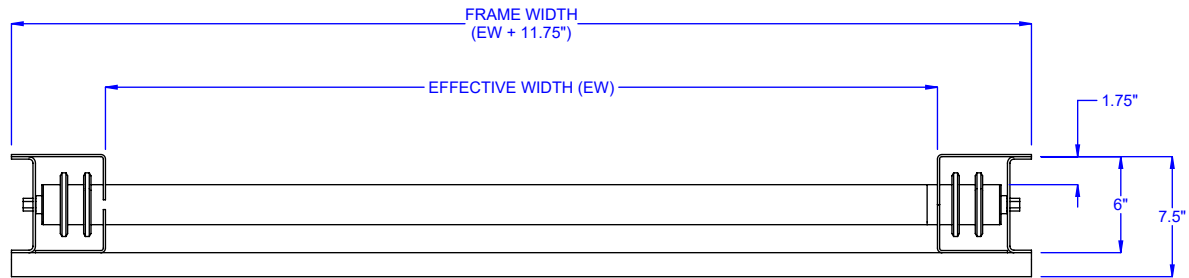

OPTIONAL FRAME
FORMED 8 GA. CHANNEL, 6" x 1-1/2"

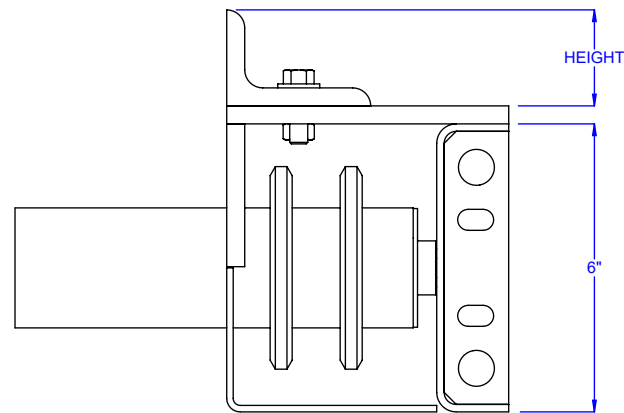

OPTIONAL
GUARDRAIL

MODEL: CDDB25

DESCRIPTION: CHAIN DRIVEN LIVE ROLLER CONVEYOR, DUAL CHAIN BOX

LEWCO, INC. IS COMMITTED TO CONTINUOUS
 IMPROVEMENT AND RESERVES THE RIGHT TO CHANGE
 DESIGNS AND SPECIFICATIONS WITHOUT NOTICE.

THIS DRAWING MUST NOT BE COPIED, REPRODUCED
 OR USED FOR ANY PURPOSE WITHOUT THE WRITTEN
 CONSENT OF LEWCO, INC. ALL RIGHTS RESERVED.



706 LANE ST. SANDUSKY, OH 44870, U.S.A.