

Model: BPD

Non-Powered Ball Transfer Table Conveyor, Drop-In Frame

Ball Transfers are used to manually rotate, reposition, or remove flat bottom surfaced products easily and efficiently. Model BPD is specifically designed to replace rollers in existing frame section of gravity roller conveyor.

Width Between Frames

- 9" to 51"

Length

- 2" to 24"

Ball Centers

- 2", 3", 4", 6"
- Dense (1.81" x 1.56")
- 3" Staggered

Construction

- Formed 12ga. steel pan with 7/16" holes for attaching to frame rail.

Load Capacity

- Varies based on how many balls the product will be in contact with at any given time. With an evenly distributed load, it's generally safe to use 4x the capacity of an individual ball as the total table capacity.

Ball Type

- 1" dia. carbon steel ball in a zinc plated housing, unsealed, 1/4"-20 UNC stud. Each ball is rated for a capacity of 65 LBS. *Note:* due to the surface flange design of this ball, it cannot be used for dense ball centers.
- Optional:
 - 50 LB. capacity steel ball, sealed.
 - 50 LB. capacity nylon ball, unsealed.
 - 75 LB. capacity steel ball, sealed.
 - 100 LB. capacity stainless steel ball & housing, unsealed.

Table Color

- Blue (RAL 5017)
- Optional:
 - Light Gray (RAL 7035)
 - Repose Gray (not an RAL)
 - Patina Green (RAL 6000)
 - Signal White (RAL 9003)
 - Jet Black (RAL 9005)
 - Flat Black (not an RAL)
 - Custom colors available

Additional Options

- Custom sizes and features available. Please consult a LEWCO Applications Engineer for more information.

Quality Assurance

- Each unit comes complete with a (1) year warranty and is tested prior to shipment.
- Manufactured under ISO 9001 Quality Certified System.

Standard Ball Transfer



Part# PCP6435 / Option# A85

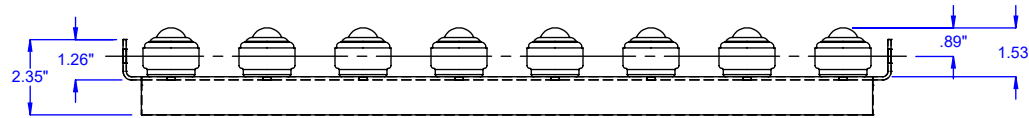
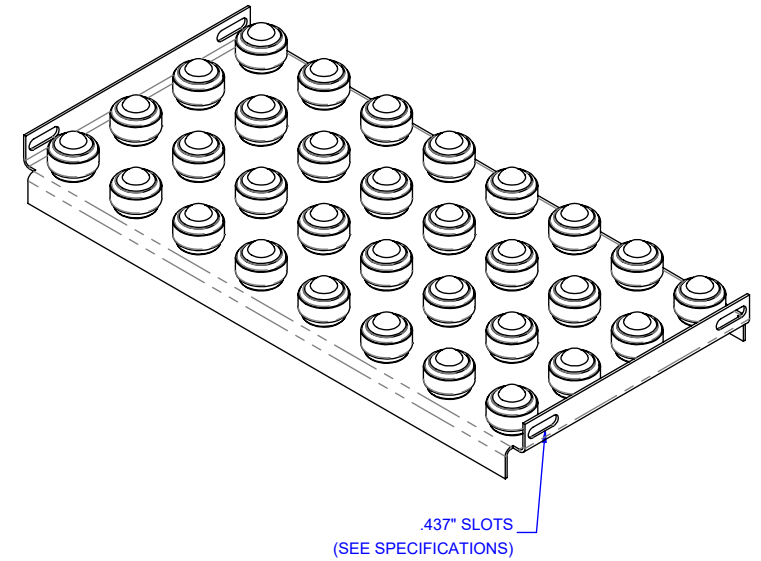
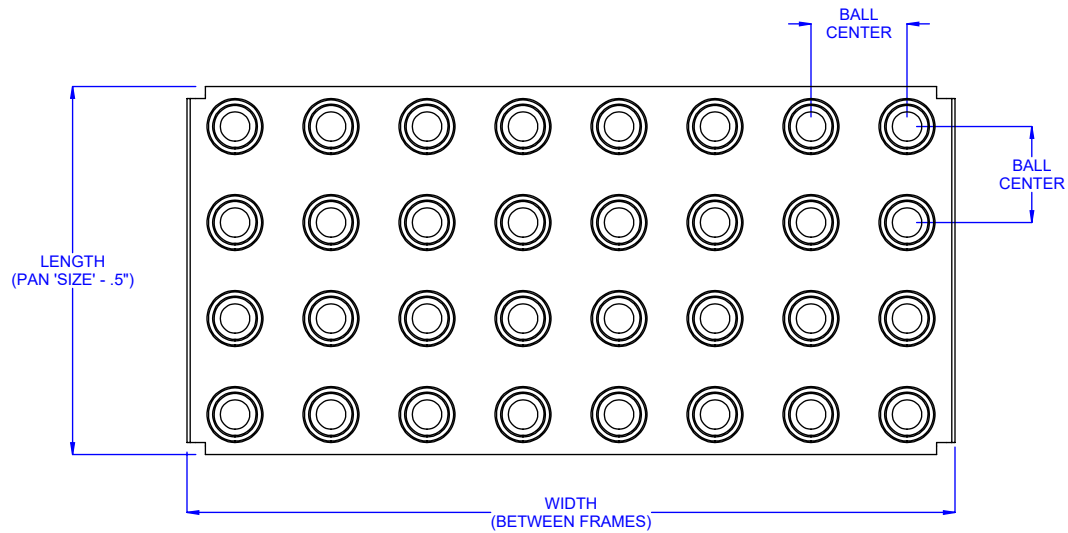

STRAIGHT BALL PATTERN

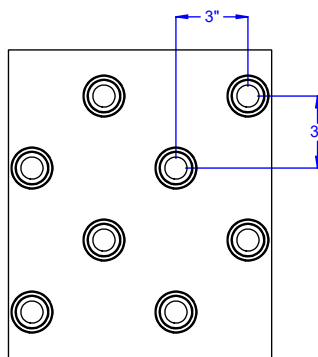

STAGGERED BALL PATTERN

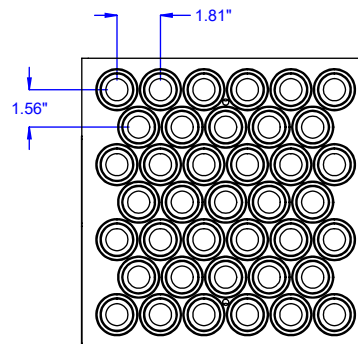

DENSE BALL PATTERN
(SOME BALLS ARE NOT AT THE DIMENSIONS SHOWN)

SPECIFICATIONS									
BALL CENTERS:	DENSE PATTERN	STRAIGHT PATTERN				STAGGERED PATTERN			
		2"	3"	4"	6"	2"	3"	4"	6"
BALLS PER SQ. FT.	39	36	16	9	4	18	8	4	2

HOLE NOTES: Hole locations vary based on table size

MODEL: BPD

DESCRIPTION: BALL TRANSFER TABLE, STYLE D, DROP-IN

LEWCO, INC. IS COMMITTED TO CONTINUOUS IMPROVEMENT AND RESERVES THE RIGHT TO CHANGE DESIGNS AND SPECIFICATIONS WITHOUT NOTICE.

THIS DRAWING MUST NOT BE COPIED, REPRODUCED OR USED FOR ANY PURPOSE WITHOUT THE WRITTEN CONSENT OF LEWCO, INC. ALL RIGHTS RESERVED.



706 LANE ST. SANDUSKY, OH 44870, U.S.A.