

Model: NPTG25LP

Non-Powered Turntable with Gravity Conveyor, 2.5" dia. Rollers, Low Profile

Turntable conveyors rotate unit loads to change the direction of travel while maintaining product orientation. They can also be used to reverse the orientation of a product or allow a pass through depending on application requirements.

Between Frames

- 27" to 61"

Length

- 24" to 48"

Roller Centers

- 4.5"

Height Elevation

- 8" to 10"
- For elevations above 10", see model NPTG25.

Rollers

- 2.5" dia. x 11ga. mild steel tube with 11/16" hex axle, spring retained, with precision, greased packed ABEC bearings.
- Optional:
 - Cotter pin retained axle
 - Galvanized roller tube
 - Polyurethane roller sleeve

Rotation

- 360 degrees, detented at 90 degree increments.

Construction

- Formed 8ga. channel rails with rollers set 1/4" high.
- Turntable is 3/8" plate with a slewing ring center bearing.

Transition Sections

- Optional transition sections can be added. See drawings for additional detail.

Turntable Color

- Blue (RAL 5017)
- Guards are yellow (RAL 1023)
- Moving parts are bright red orange (RAL 2008).
- Optional:
 - Light Gray (RAL 7035)
 - Repose Gray (not an RAL)
 - Patina Green (RAL 6000)
 - Signal White (RAL 9003)
 - Jet Black (RAL 9005)
 - Flat Black (not an RAL)
 - Custom colors available

Additional Options

- Guardrail
- End Stops
- Custom sizes and features available. Please consult a LEWCO Applications Engineer for more information.

Quality Assurance

- Each unit comes complete with a (1) year warranty and is tested prior to shipment.
- Manufactured under ISO 9001 Quality Certified System.

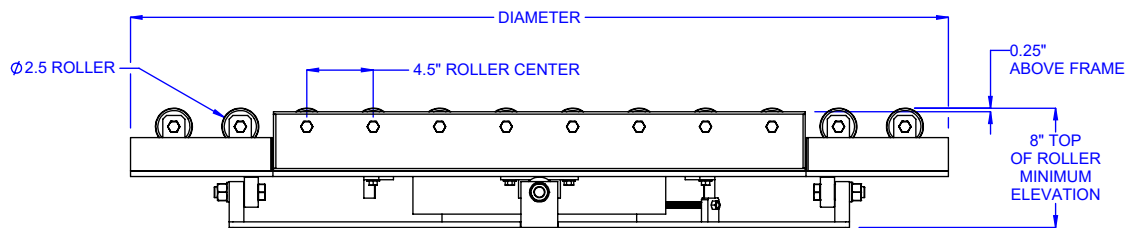
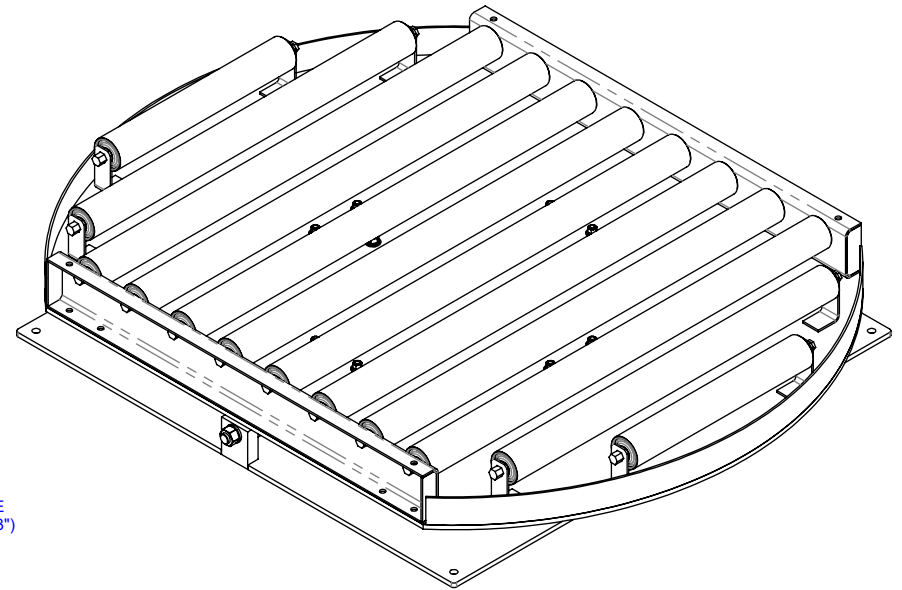
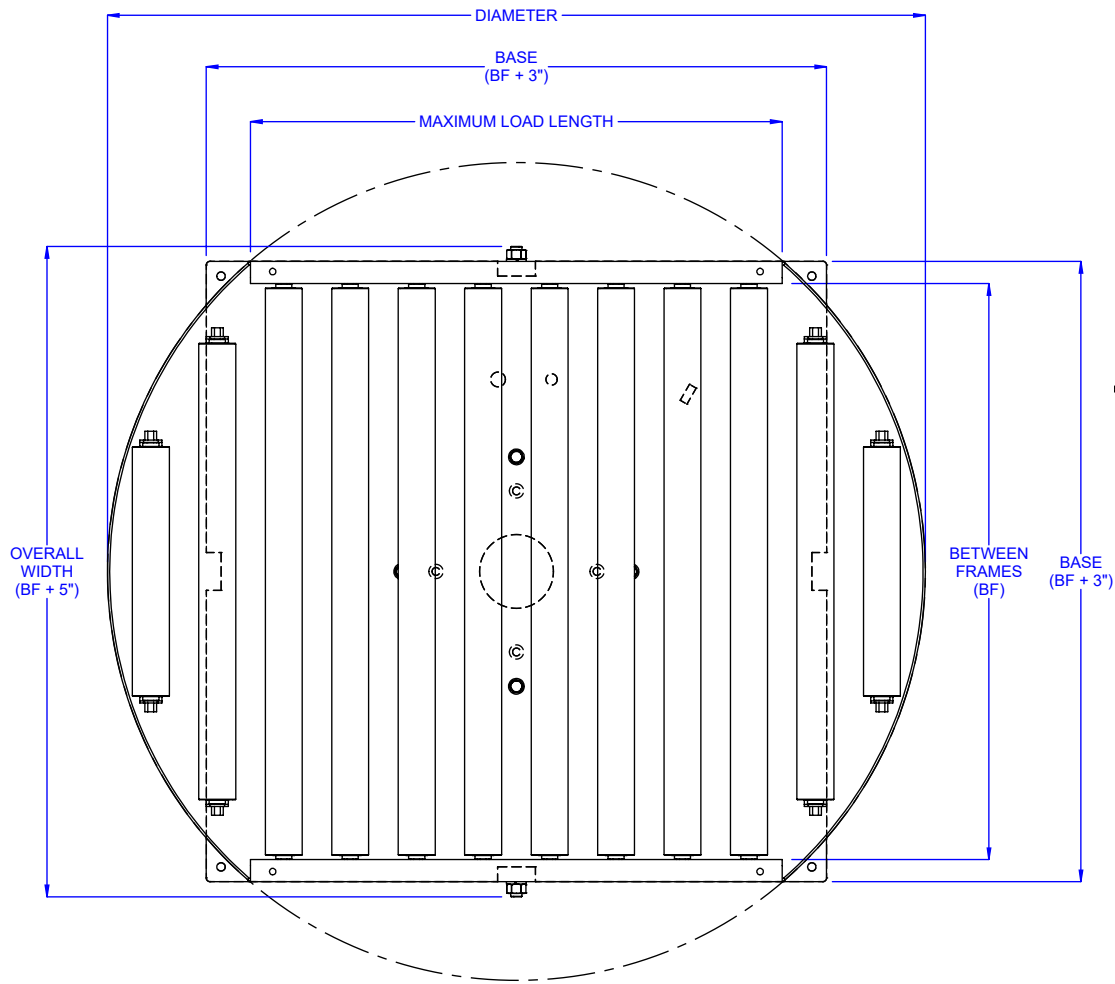

BETWEEN FRAMES	MAXIMUM LOAD LENGTH	DIAMETER
27"	27"	40.38"
33"	32"	48.25"
39"	36"	55.38"
45"	45"	65.88"
51"	50"	73.63"
55"	54"	79.25"
57"	54"	80.75"
61"	63"	89.88"

MINIMUM BETWEEN FRAMES: 27"

ELEVATION: 8" TO 10"

LOAD CAPACITY: 2000 LB MAXIMUM LOAD DISTRIBUTED ON TURNTABLE

MODEL: NPTG25LP

DESCRIPTION: NON-POWERED TURNTABLE WITH GRAVITY CONVEYOR, LOW PROFILE

LEWCO, INC. IS COMMITTED TO CONTINUOUS IMPROVEMENT AND RESERVES THE RIGHT TO CHANGE DESIGNS AND SPECIFICATIONS WITHOUT NOTICE.

THIS DRAWING MUST NOT BE COPIED, REPRODUCED OR USED FOR ANY PURPOSE WITHOUT THE WRITTEN CONSENT OF LEWCO, INC. ALL RIGHTS RESERVED.



706 LANE ST. SANDUSKY, OH 44870, U.S.A.

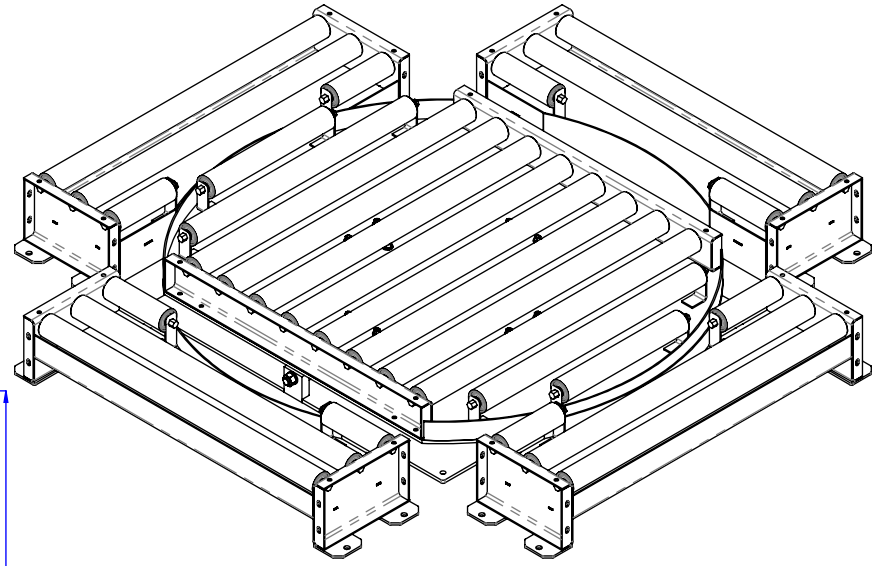
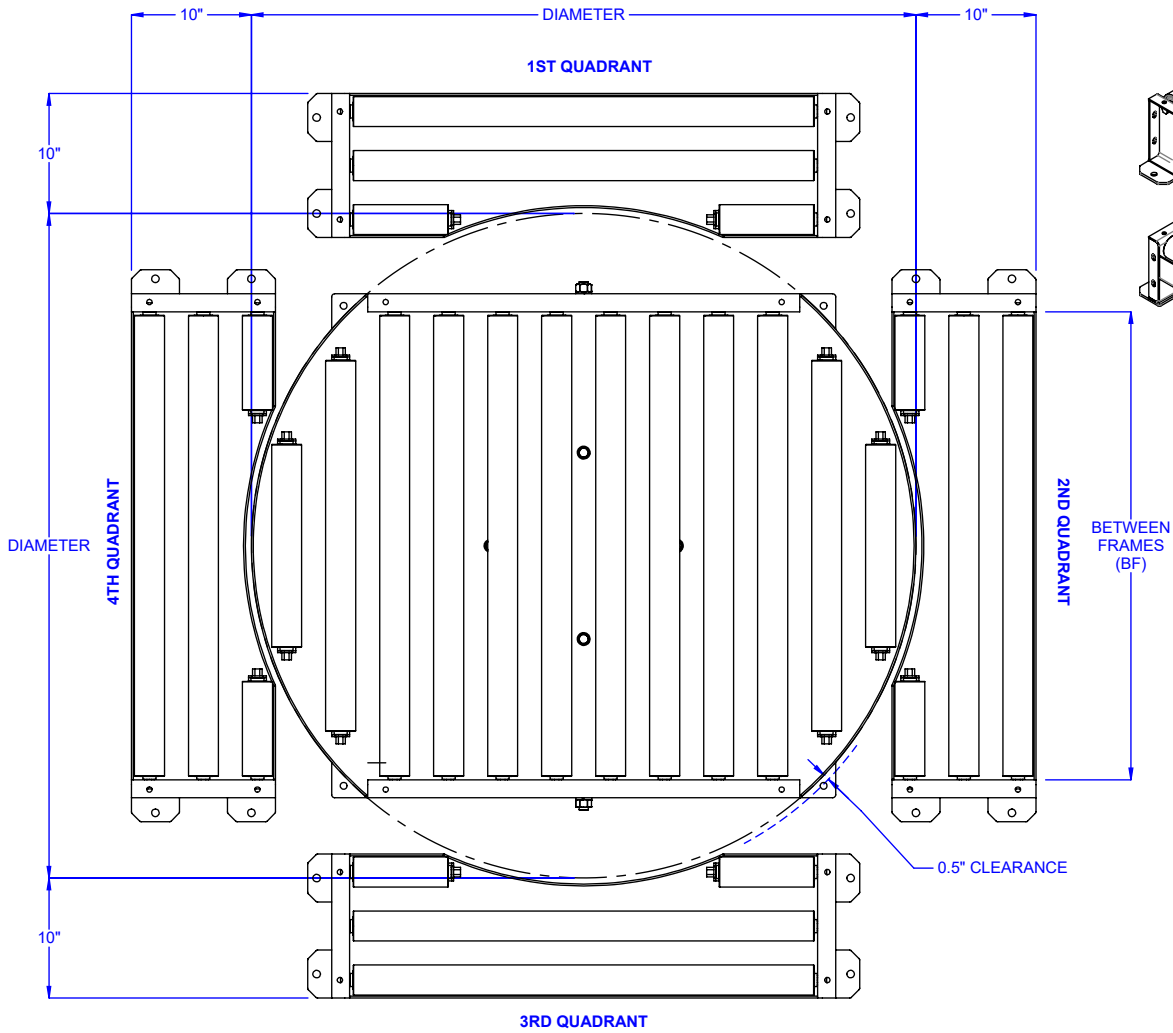

TRANSITION OPTIONS

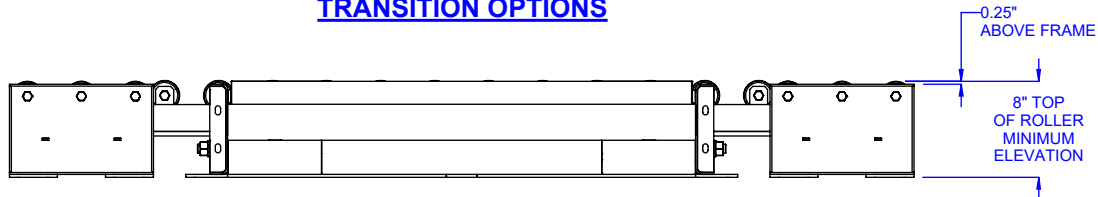

MODEL: NPTG25LP

DESCRIPTION: NON-POWERED TURNTABLE WITH GRAVITY CONVEYOR, LOW PROFILE

LEWCO, INC. IS COMMITTED TO CONTINUOUS IMPROVEMENT AND RESERVES THE RIGHT TO CHANGE DESIGNS AND SPECIFICATIONS WITHOUT NOTICE.

THIS DRAWING MUST NOT BE COPIED, REPRODUCED OR USED FOR ANY PURPOSE WITHOUT THE WRITTEN CONSENT OF LEWCO, INC. ALL RIGHTS RESERVED.



706 LANE ST. SANDUSKY, OH 44870, U.S.A.