



Model: CDLR35

Chain Driven Live Roller Conveyor, 3.5" dia.

Chain driven roller conveyor is the workhorse of heavy-duty material handling and is an excellent choice for moving large automotive racks, structural steel beams, castings, and other heavy loads. Its rugged welded frame construction can withstand the most abusive of environments. Chain driven roller conveyor also provides versatility in production lines because it can easily incorporate with chain transfers and turntables.

Effective Width

- 13" to 84"

Length

- 48" to 900"

Roller Centers

- 6", 7.5", or 12"

Rollers

- 3.5" dia. x .30 wall mild steel tube with 1" hex axle, cotter pin retained, with precision, greased packed ABEC bearings, and #60 sprockets.
- Optional:
 - Zinc plated roller tube
 - Polyurethane roller sleeve
 - Ultrex accumulation sleeves

Frame Construction

- Structural channel, 8"x11.5# on chain box side & 6"x8.2# on opposite side with rollers set 3/8" high
- Optional:
 - Structural channel, 8"x11.5# with rollers set 1-5/8" low

Drive Location

- Standard drive is mounted high near center of conveyor length on chain box side.
- Optional:
 - Drive mounted low or drive mounted below and within frame, near center.

Motor

- 1/2 HP to 3 HP
- Totally Enclosed Fan Cooled motor
- Optional:
 - Inverter Duty motor
 - Power Off Brake motor
- Voltage: 230/460/ 3Ph/ 60hz
- Optional:
 - 115V/ 1Ph/ 60Hz
 - 208V/ 1Ph/ 60Hz
 - 230V/ 1Ph/ 60Hz
 - 575V/ 3Ph/ 60Hz
 - 24VDC

Speed

- 10 to 120 FPM (feet per minute)

Control Options

- Variable Speed Controller
- Combination motor starter with disconnect, fixed speed
- Combination motor starter with disconnect, variable speed
- PLC with HMI
- No controls (provided by others)

Conveyor Color

- Blue (RAL 5017)
- Guards are yellow (RAL 1023)
- Moving parts are bright red orange (RAL 2008).
- Optional:
 - Light Gray (RAL 7035)
 - Repose Gray (not an RAL)
 - Patina Green (RAL 6000)
 - Signal White (RAL 9003)
 - Jet Black (RAL 9005)
 - Flat Black (not an RAL)
 - Custom colors available

Additional Options

- Conveyor Supports
- Guardrail
- Fork Truck Barriers
- Photo Eye Sensor(s)
- Custom sizes and features available. Please consult a LEWCO Applications Engineer for more information.

Quality Assurance

- Each unit comes complete with a (1) year warranty and is tested prior to shipment.
- Manufactured under ISO 9001 Quality Certified System.

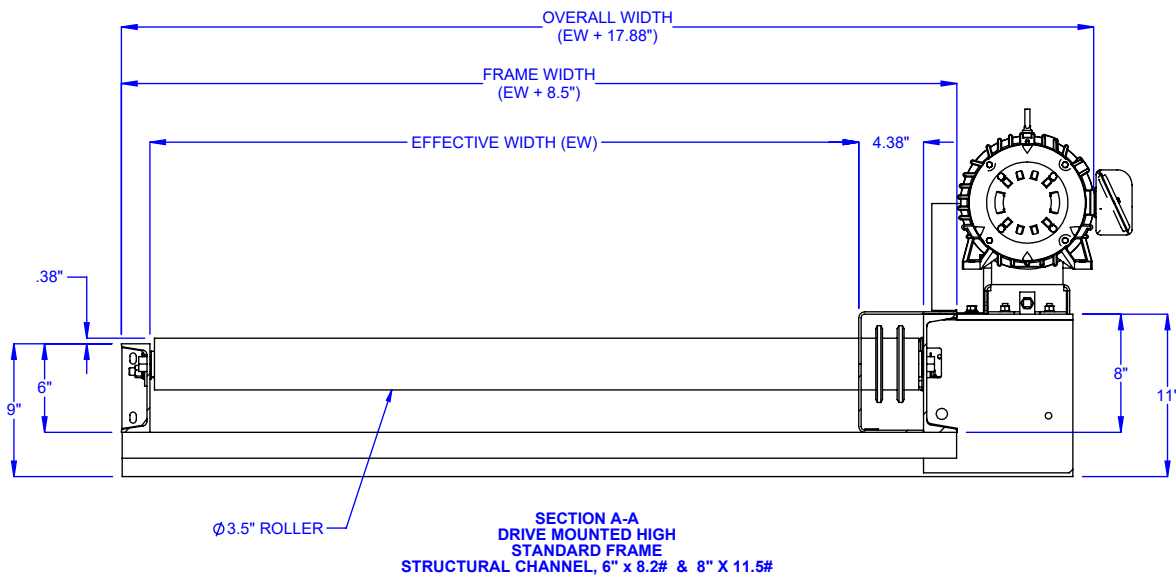
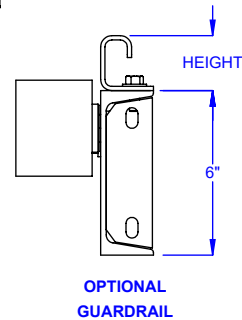
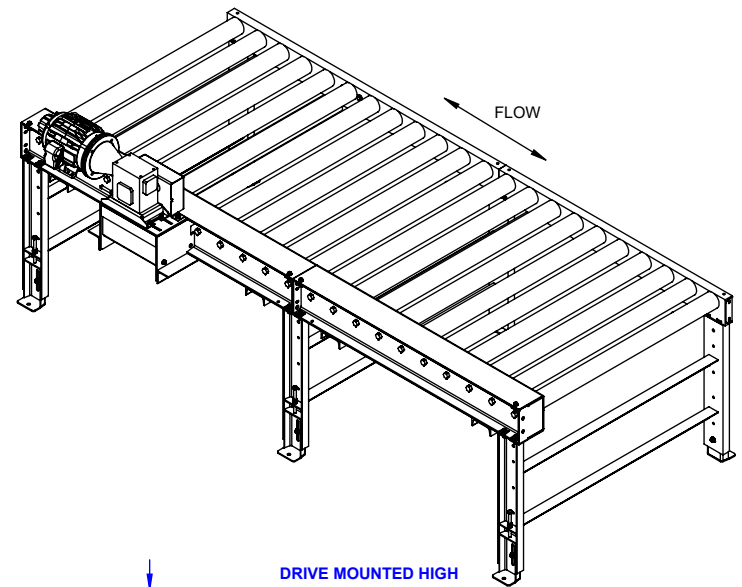
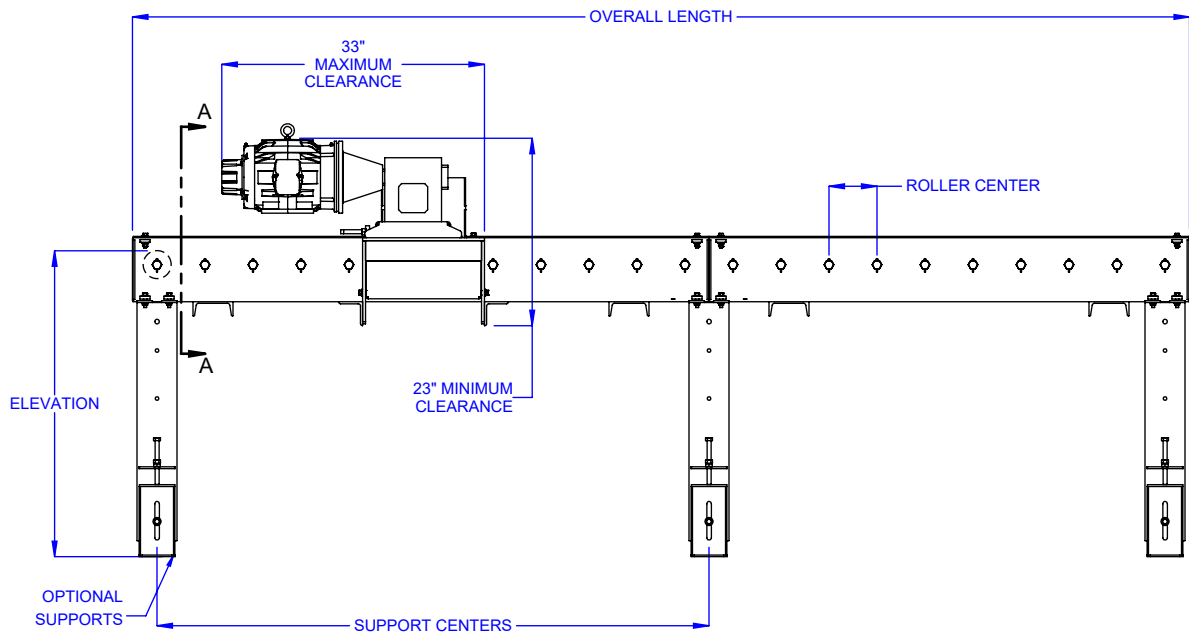

LOAD CAPACITY (LBS) @ 60 FPM 6" ROLLER CENTERS			
HP	WIDTH		
	36"	60"	84"
1/2	300	-	-
3/4	1250	400	-
1	2200	1350	550
1 1/2	5050	4200	3400
2	9050	8200	7400
3	14350	13550	12750
LOAD CAPACITY (LBS) @ 30 FPM 6" ROLLER CENTERS			
HP	WIDTH		
	36"	60"	84"
1/2	2850	2000	1200
3/4	5050	4250	3400
1	9050	8250	7450
1 1/2	14400	13550	12750
2	19700	18900	18100
3	30400	29550	28750
MAXIMUM LOAD PER LINEAR FOOT OF CONVEYOR IS 2000 LBS - NOT TO EXCEED CAPACITY ABOVE			

* Based on 20 FT. length. Note: HP requirements will vary for different drive options, conveyor lengths, roller centers, pallet types and chain lubrication conditions. Consult factory.

MODEL: CDLR35

DESCRIPTION: CHAIN DRIVEN LIVE ROLLER CONVEYOR

LEWCO, INC. IS COMMITTED TO CONTINUOUS IMPROVEMENT AND RESERVES THE RIGHT TO CHANGE DESIGNS AND SPECIFICATIONS WITHOUT NOTICE.

THIS DRAWING MUST NOT BE COPIED, REPRODUCED OR USED FOR ANY PURPOSE WITHOUT THE WRITTEN CONSENT OF LEWCO, INC. ALL RIGHTS RESERVED.

LEWCO

706 LANE ST. SANDUSKY, OH 44870, U.S.A.

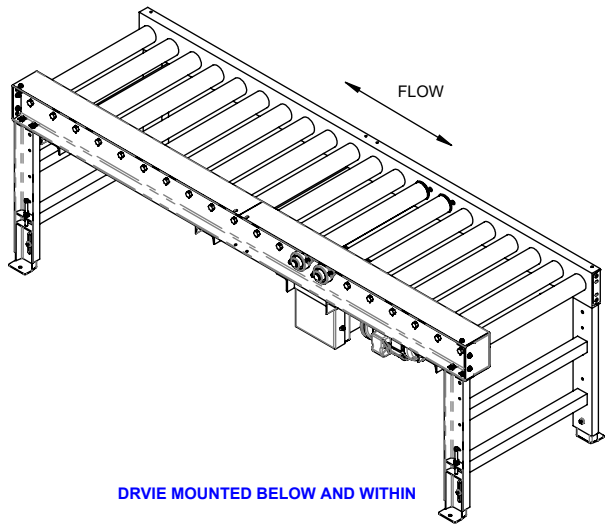

DRIVE MOUNTED BELOW AND WITHIN

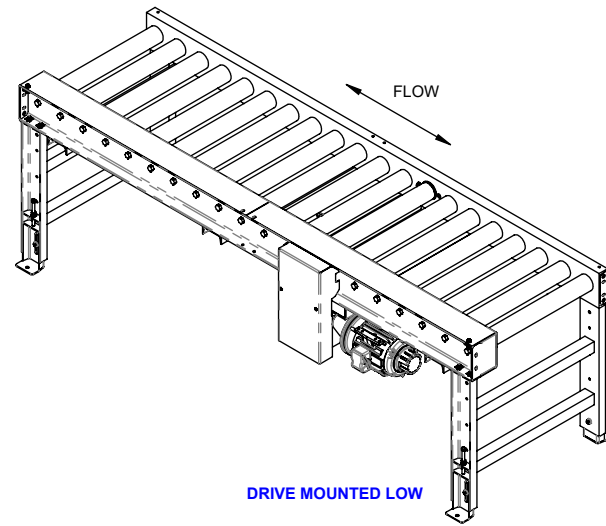

DRIVE MOUNTED LOW

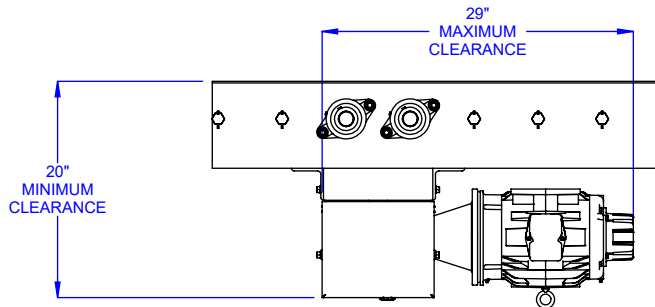

DRIVE MOUNTED
BELOW AND WITHIN
OPTION

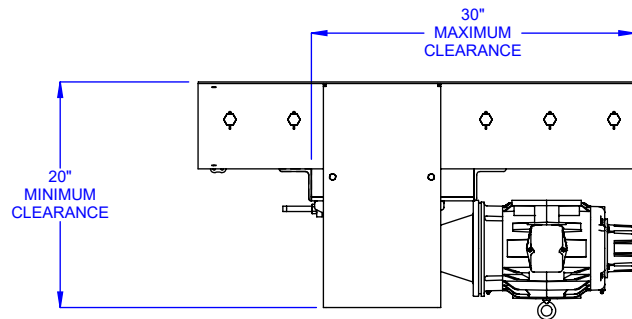

DRIVE MOUNTED LOW
OPTION

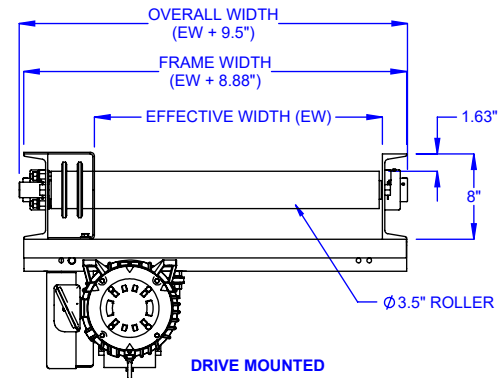

DRIVE MOUNTED
BELOW AND WITHIN
END VIEW

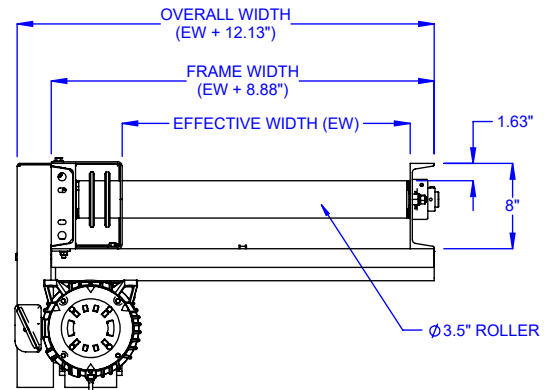

DRIVE MOUNTED LOW
END VIEW

MODEL: CDLR35

DESCRIPTION: CHAIN DRIVEN LIVE ROLLER CONVEYOR

LEWCO, INC. IS COMMITTED TO CONTINUOUS IMPROVEMENT AND RESERVES THE RIGHT TO CHANGE DESIGNS AND SPECIFICATIONS WITHOUT NOTICE.

THIS DRAWING MUST NOT BE COPIED, REPRODUCED OR USED FOR ANY PURPOSE WITHOUT THE WRITTEN CONSENT OF LEWCO, INC. ALL RIGHTS RESERVED.



706 LANE ST. SANDUSKY, OH 44870, U.S.A.

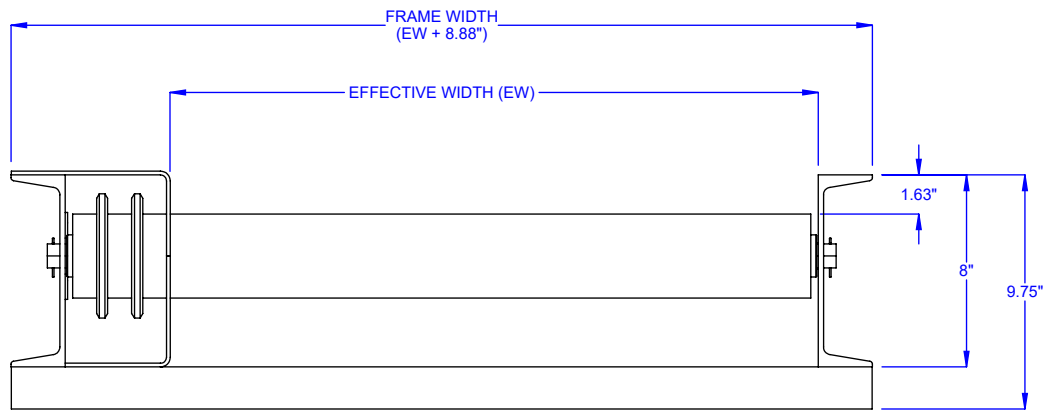

OPTIONAL FRAME
STRUCTURAL CHANNEL, 8" x 11.5#

MODEL: CDLR35

DESCRIPTION: CHAIN DRIVEN LIVE ROLLER CONVEYOR

LEWCO, INC. IS COMMITTED TO CONTINUOUS IMPROVEMENT AND RESERVES THE RIGHT TO CHANGE DESIGNS AND SPECIFICATIONS WITHOUT NOTICE.

THIS DRAWING MUST NOT BE COPIED, REPRODUCED OR USED FOR ANY PURPOSE WITHOUT THE WRITTEN CONSENT OF LEWCO, INC. ALL RIGHTS RESERVED.



706 LANE ST. SANDUSKY, OH 44870, U.S.A.