



# Owner's Manual

## Model 40SB Low Profile Slider Bed Belt Conveyor

## TABLE OF CONTENTS

<b>WARRANTY</b> .....	1
<b>INTRODUCTION</b> .....	2
<b>SECTION 1 – SAFETY</b> .....	3
1-1 SAFETY SIGNS & DEFINITIONS.....	3
1-2 SAFETY CONSIDERATIONS.....	4
1-3 EMERGENCY SHUT-DOWN.....	4
1-4 GAURDS & GUARDING.....	5
<b>SECTION 2 – INSTALLATION</b> .....	5
2-1 SUPPORT INSTALLATION.....	5
2-2 CONVEYOR SET-UP.....	6
2-3 BELT INSTALLATION & TRACKING PROCEDURE.....	6
2-4 PRE-START CHECKS.....	7
<b>SECTION 3 – MAINTENANCE</b> .....	7
3-1 MAINTENANCE INTERVALS.....	8
3-3 MAINTENANCE PROCEDURES.....	8
3-3 REPLACEMENT PARTS.....	9
<b>SECTION 5 – TROUBLESHOOTING</b> .....	10

# LEWCO, Inc.

# Warranty

## Conveyor Products

**NOTE: This warranty supersedes all previous editions.**

**Seller's warranty as stated herein shall be effective only upon payment in full by the Buyer for the affected goods and/or services.**

Every LEWCO, Inc. product has been carefully inspected before shipment and we guarantee to correct any defect caused by faulty material or workmanship. Seller's obligation under this warranty is for one year or 4000 hours of use, whichever comes first, after shipment of products or equipment. The Seller warrants that the equipment furnished and the material used in its manufacturing shall be of good quality and free from defects. Subject to the conditions stated herein, the Seller will replace (F.O.B. Sandusky, OH) or repair any equipment proving defective in material or workmanship. Defect(s) to be verified by Seller's inspection upon receiving products or equipment at Seller's plant. Cost for shipping of defective and/or replacement parts to be incurred by Buyer. Credit for return shipping charges may be issued to the Buyer after any and all inspections are concluded. Failure due to abuse, overloading, maintenance neglect, exposure to corrosive or abrasive materials, or improper use shall not be subject to said warranty. Any modification to equipment or systems without Seller's written consent voids this warranty. Component parts not of Seller's manufacture (such as motors, fans and reducers) will be covered by the original manufacturer's warranty and not by Seller. In the case of failure during the warranty period, contact your Seller's representative or the nearest authorized service representative of the manufacturer. Standard warranty does not include labor to remove and/or install defective equipment. If a Seller's Representative is required for additional assistance, contact our Customer Service Department. Labor will be charged at a prevailing rate, plus travel expenses. Seller shall not be liable for loss of profits, delays or expenses incurred by failure of said parts, whether incidental or consequential. Except as stated herein, the Seller makes no other warranties, expressed or implied, including warranties of merchantability and fitness for a particular purpose. There are no warranties, which extend beyond the description on the face thereof. Buyer's exclusive remedy for claims arising hereunder shall be for damages. The Seller's alleged liability for defective products or equipment, irrespective of whether such defects are discoverable or latent, shall in no event exceed the cost to the Seller of repairing, at the Seller's option, the defective or damaged products or equipment. In no event, including in the cost of a claim of negligence, shall the Seller be liable for incidental or consequential damage. The Seller makes no warranties or representations, express or implied, with respect to the product or any service, advice or consultation, if any, furnished to the Buyer by any other party, by the Seller or its representatives. Seller shall not be liable for any loss, personal injury or property damage directly or indirectly arising from the use of its product, advice or service, or for incidental, consequential or punitive damages of any description, whether any such claim be based on warranty, contract, negligence, strict liability or other tort, or otherwise. No deviation from these standard Terms and Conditions of Warranty will be recognized or allowed unless prior written authorization is obtained by Buyer, from Seller.



## INTRODUCTION

Thank you for choosing LEWCO, Inc. for your material handling needs. This manual has been prepared by LEWCO engineers for use in familiarizing personnel with the design, installation, operation and maintenance of LEWCO Conveyor Products. Information presented herein should be given careful consideration to assure safe, optimum performance of the equipment. This manual should always be accessible to the operators for quick reference.

This equipment has been designed and manufactured in accordance with applicable National Codes and Standards in effect as of the date of manufacture. It is the responsibility of the end user to update equipment as necessary to comply with future code changes or revisions.

This manual should be used in conjunction with the drawing(s), data sheets, and component manufacturer's literature attached hereto that clarify specific features, installation, utility connections, operation, etc.

If you have any questions regarding this manual or the use of your LEWCO Conveyor Products, please contact us by phone at (419) 625-4014 ext. 4003 or by email at [conveyorsales@lewcoinc.com](mailto:conveyorsales@lewcoinc.com).

**NOTE:** The information in this manual is subject to change without notice and does not represent an obligation on the part of LEWCO, Inc. LEWCO does not assume any responsibility for any errors that may appear in this manual and under no circumstances will LEWCO be held liable for technical or editorial omissions made herein, nor for direct, indirect, special, incidental, or consequential damages resulting from the use or defect of this manual.



**NOTICE:** No installation or operation of this equipment should take place until this manual has been studied and understood by the person(s) responsible.

Copyright © 2016 by LEWCO, Inc.

All rights reserved. Reproduction or copying of this manual by any means, electronic or mechanical, including photocopying, recording, or information storage and retrieval systems is not permitted without the written permission of LEWCO, Inc.

## SECTION 1 – SAFETY

To reduce the possibility of injury to personnel operating, or in the vicinity of LEWCO conveying equipment, safety signs are posted at potential hazard points on the equipment. Examine this equipment and become familiar with potential hazard areas. Additionally, instruct all personnel to heed these potential hazard areas.

### 1-1 SAFETY SIGNS & DEFINITIONS

Manual Specific Safety Symbol Definitions	
	Safety Instruction where an electrical hazard is involved.
	Safety instruction where non-compliance would affect safety.
	Safety instruction relating to safe operation of the equipment (ATTENTION).
	Safety instruction where non-compliance could potentially result in a pinch point or a description of a known existing pinch point.
	Safety instruction where non-compliance could potentially result in a pinch point or a description of a known existing pinch point.
	Indicates a hazardous situation which, if not avoided, will result in death or serious injury. The signal word "DANGER" is to be limited to the most extreme situations. DANGER [signs] should not be used for property damage hazards unless personal injury risk appropriate to these levels is also involved.
	Indicates a hazardous situation which, if not avoided, could result in death or serious injury. WARNING [signs] should not be used for property damage hazards unless personal injury risk appropriate to this level is also involved.
	Indicates a hazardous situation which, if not avoided, could result in minor or moderate injury. CAUTION [signs] without a safety alert symbol may be used to alert against unsafe practices that can result in property damage only.
	Is used to describe preferred to address practices not related to personal injury.
Equipment Specific Safety Signs & Definitions	
	<b>DANGER:</b> Climbing, sitting, walking or riding on conveyor at any time will cause severe injury or death. Keep Off.
	<b>WARNING:</b> servicing moving or energized equipment can cause severe injury. LOCK OUT POWER before servicing.
	<b>WARNING:</b> exposed moving parts can cause severe injury. LOCK OUT POWER before removing guard.
	<b>WARNING:</b> Moving equipment may cause severe injury. Keep Away.
	<b>WARNING:</b> Potential arc flash hazard.

## 1-2 SAFETY CONSIDERATIONS



### WARNING



- Disconnect and lockout electrical power and all other sources of energy before performing maintenance. Follow proper lockout/ tag out procedures. Know where arc flash is possible and take proper precautions.



- Do not have long hair, jewelry, or loose clothing while operating or near the conveyor, as these are potential hazards that could cause entanglement.
- Do not operate equipment without proper guards in place, as bodily injury may result.



- Pinch points may exist. Inspect equipment for potential pinch points and use caution.



### CAUTION

- This equipment is to be operated by trained personnel only. Operators should be trained under normal and emergency conditions.
- Personnel operating or near the conveyor should be instructed as to the location of stopping devices. Ensure stopping devices are kept free of obstruction.
- Personnel operating or near the conveyor should watch for and be aware of conveying hazards, such as sharp edges, protruding parts, etc.
- Ridding on conveyor is strictly prohibited, as serious injury may result.
- Prior to starting conveyor, ensure no work is being performed, all guards are in place, and inspect for foreign objects that could injure personnel or damage equipment.
- Operators should always alert personnel in the area prior to starting the conveyor.
- This equipment may create hazards. The owner is responsible for analyzing the installation of this equipment in order to make determinations regarding the posting of warning signs in order to comply with applicable OSHA standards.
- Conveyor should only be used to transport materials or items that it is originally intended and designed to handle.
- Do not load conveyor beyond its designed handling capacity.
- Keep area around loading and unloading points of conveyor free from obstructions.
- Check belt tracking to make sure it is running straight on the conveyor.
- After starting conveyor, make sure all areas of the conveyor are operating properly.
- Poor housekeeping practices can cause accidents. Keep conveyor and surrounding area clean from spilled lubrications and other materials.
- Always use extreme caution when using mechanical aids, such as hoists, cables, and other equipment to install or perform maintenance on conveyor. They can cause damage to the conveyor and cause a dangerous condition when the conveyor is turned on.

## 1-3 EMERGENCY SHUT-DOWN

In the event of an emergency, the following steps should be followed:

1. Press emergency stop button. If access to emergency stop button(s) is restricted, turn off the electrical disconnect providing power to the conveyor.
2. Depending on the severity of the issue, restrict access to the area until the issue has been resolved.

## 1-4 GUARDS & GUARDING

All LEWCO standard conveyor equipment is equipped with standard machine guarding methods. It is the responsibility of the owner, however, to ensure that proper guarding methods are present to comply with OSHA Standards – 29 CFR – 1910.212 Machinery and Machine Guarding. Special consideration should be given to areas where multiple pieces of equipment interface. The following are links are provided for reference:

[1910.212\(a\)](#): *Machine guarding.*

[1910.212\(a\)\(1\)](#): *Types of guarding.* One or more methods of machine guarding shall be provided to protect the operator and other employees in the machine area from hazards such as those created by point of operation, ingoing nip points, rotating parts, flying chips and sparks. Examples of guarding methods are barrier guards, two-hand tripping devices, electronic safety devices, etc.

[1910.212\(a\)\(2\)](#): *General requirements for machine guards.* Guards shall be affixed to the machine where possible and secured elsewhere if for any reason attachment to the machine is not possible. The guard shall be such that it does not offer an accident hazard in itself.

[1910.212\(a\)\(3\)](#): *Point of operation guarding.*

[1910.212\(a\)\(3\)\(i\)](#): Point of operation is the area on a machine where work is actually performed upon the material being processed.

[1910.212\(a\)\(3\)\(ii\)](#): The point of operation of machines, whose operation exposes an employee to injury, shall be guarded. The guarding device shall be in conformity with any appropriate standards thereof, or, in the absence of applicable specific standards, shall be so designed and constructed as to prevent the operator from having any part of his body in the danger zone during the operating cycle.

[1910.212\(a\)\(3\)\(iii\)](#): Special hand tools for placing and removing material shall be such as to permit easy handling of material without the operator placing a hand in the danger zone. Such tools shall not be in lieu of other guarding required by this section, but can only be used to supplement protection provided.

## SECTION 2 – INSTALLATION

### 2-1 SUPPORT INSTALLATION

- Bolts for attaching the supports to the bed sections are shipped in a bag attached to the supports or in a separate box.
- Set the support height. Subtract frame height dimension from desired conveying surface. See *Figure 2.1*. Adjust the supports to this dimension by sliding inner and outer legs and tighten bolts.
- Supports should be located at ends of conveyor and centered under each splice on multi-piece conveyors (nominal 10' centers).
- If supports are located on nominal 5' centers, center additional supports midway between supports at splices.

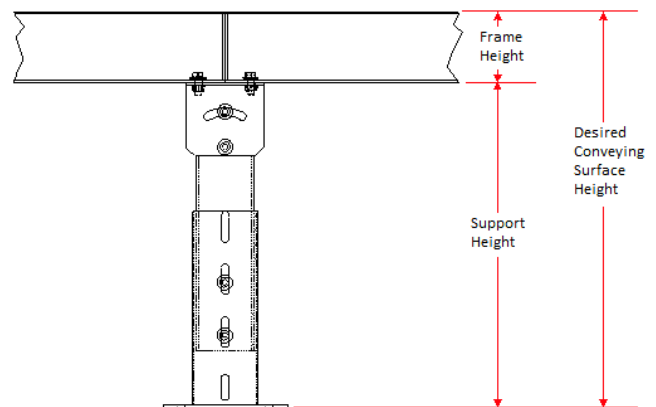

**Figure 2.1** – Support Height Adjustment

## 2-2 CONVEYOR SET-UP

- Mark a chalk line on floor to locate center of the conveyor.
- Place the drive section in position.
- Install remaining sections in order. Conveyor sections have a section number label, which includes the Sales Order number, Line Item number, and Section Assembly number (last two digits). Conveyors made up of more than one section are to be assembled in ascending numerical order, starting with Section Assembly 01 at the product infeed end.
- Check that conveyor is level across both width and length of conveyor. Adjust supports if necessary.
- Check all bed sections for square. See *Figure 3.1*. Use a string stretched from opposing corners at edge of bed to aid in straightening conveyor. Ensure that both dimensions are the same. Adjust or shim supports as required. Both sides of the conveyor must be in the same plane (bed not twisted).
- Tighten all butt couplings and support mounting bolts and lag conveyor to floor.
- Install and track belt.

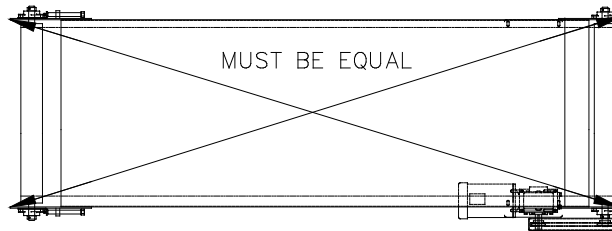

**Figure 3.1** - Check the bed for square

## 2-3 BELT INSTALLATION & TRACKING PROCEDURE

- Install belt per *Figure 4.1*.
- Prior to starting the conveyor, again ensure that all pulleys and rollers are square and level. Initially, avoid the situation shown in *Figure 4.2*.
- Start the conveyor.
- Check for proper belt tension. When properly adjusted, there should be no slippage between the drive pulley and the conveyor belt and the drive motor amp draw will be under the rated full load amps as indicated on the motor name-plate.
- If the belt slips on the drive pulley, more tension is required. Adjust the take-up pulley to increase the tension on the belt. Make small, even adjustments; Monitoring the results before readjusting.
- If the belt is over-tensioned, the belt lacing will pull away and the motor amp draw will be high. Adjust the take-up pulley to decrease the tension on the belt. Make small, even adjustments; monitoring the results before readjusting.
- Review belt position at all pulleys. Track belt if necessary based on *Figure 4.2*.

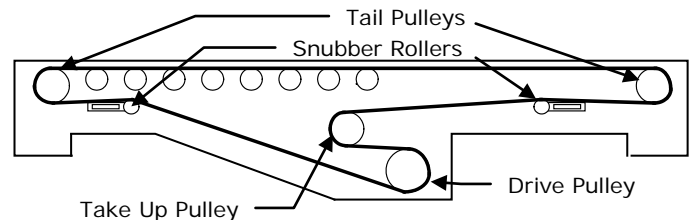

**Figure 4.1** – Center Drive Belt Routing (roller bed shown, same for slider bed)

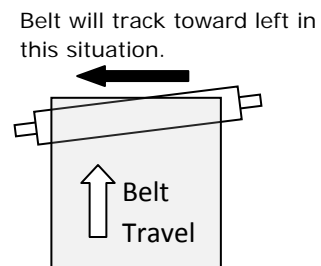
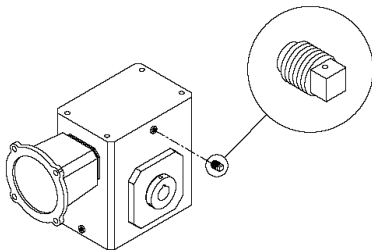

**Figure 4.2** – Pulley Adjustment for Belt Tracking (Plan View)



## 2-4 PRE-START CHECKS

- MOST speed reducers are shipped with oil, however, ALWAYS check for proper oil level before operating the conveyor.
- CHECK FOR REDUCER VENT PLUG AND INSTALL IF NECESSARY. See *Figure 5.1*. To install, remove the solid plug and replace with vent plug.
- Remove drive chain guard and inspect drive chain and sprockets.
- Chain should have sag on the slack side per *Figure 5.2*. Measure the sag half way between the two sprockets.
- Sag should be  $\frac{1}{4}$ " or 2% of the sprocket center distance.
- Inspect drive sprocket and pulley set screws. These should be tight against the reducer and pulley shafts. Using a straight edge check to assure the sprockets are aligned by placing the straight edge flush against the sprocket flanges.
- Re-install chain guard after inspection.



**Figure 5.1 –**  
Reducer Vent Plug Installation

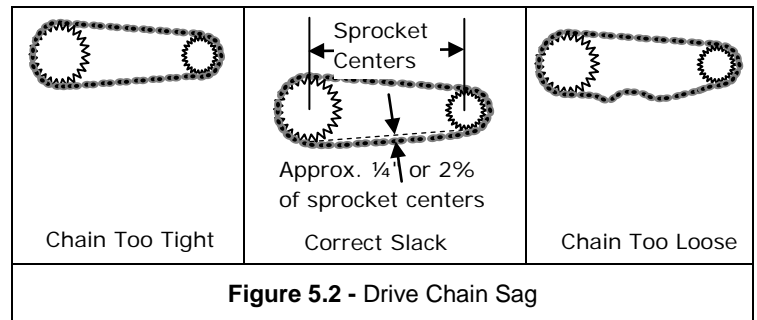

**Figure 5.2 - Drive Chain Sag**

## SECTION 3 – MAINTENANCE

Effective operation and useful life of any equipment is directly related to the care and service it receives. A pre-determined maintenance schedule, including inspection, lubrication, and cleaning, should be established for each conveyor. Establish and maintain “Log Sheets” on each conveyor to record date and results of inspections, lubrication, and parts replacements. General inspections of all conveyors should be performed at regular intervals depending on use and service conditions



**WARNING:** Do not attempt any maintenance on this equipment unless all sources of energy are disconnected and locked out by properly trained personnel.

**NOTICE:** Do not perform any work on the conveyor while it is running unless the nature of the maintenance absolutely requires operation of the conveyor. If the conveyor must be operated to perform maintenance procedures, allow only experienced conveyor maintenance personnel to do the work. Use extreme caution.

### 3-1 MAINTENANCE INTERVALS

This list of maintenance items is a general overview of the minimum items that may need to be addressed on your LEWCO Conveyor. The actual list may vary depending on the specific equipment provided. The customer should make the final determination on maintenance intervals and tasks to be performed while considering the working environment. Please review applicable component literature for further detail and potential additional maintenance items.

COMPONENT	ACTION	SCHEDULE		
		WEEKLY	MONTHLY	QUARTERLY
MOTOR	Listen for irregular noise.		✓	
	Check for overheat.	✓		
	Check mounting bolts are secure.		✓	
REDUCER	Listen for irregular noise.		✓	
	Check for overheat.		✓	
	Check oil level.			✓
DRIVE CHAIN	Check for tension.			✓
	Lubricate.	✓		
	Inspect for wear.			✓
SPROCKETS	Inspect for wear.			✓
	Check set screws and keys.			✓
BELT	Check belt tracking.		✓	
	Check for tension.		✓	
	Inspect lacing.	✓		
BEARINGS (Pulleys & Rollers)	Listen for irregular noise.		✓	
	Check mounting bolts are secure.			✓
STRUCTURAL	General check: Loose nuts, bolts, etc. Tighten as necessary.		✓	
ELECTRICAL	Inspect all wiring for secure connection. Ensure there are no loose or cut wires.		✓	
	Test Emergency Stop switches for proper function.		✓	

### 3-2 MAINTENANCE PROCEDURES

#### 3.2.1 Sprocket and Chain Maintenance

- Remove drive chain guard and inspect drive chain and sprockets.
- Chain should have ¼" or 2% sag when measured on the lower run of chain half way between the two sprockets. See "Pre-Startup Checks".
- A loose chain can jump the drive sprockets and can cause sprocket wear and failure. A tight chain requires excessive motor power, and can cause chain and sprocket failure.
- Inspect drive sprocket and pulley set screws for tightness against the reducer and pulley shafts.
- Check sprocket alignment. Misalignment causes wear on one side of the sprocket. Check for a misaligned shaft or a sprocket off center.
- Check shaft bearing set screws.
- Lubricate the drive chain with SAE-30 oil approximately every 40 hours of operation. Lubricate more frequently under extreme ambient conditions. Rinse chain in solvent before lubricating.
- Re-install chain guard after inspection and maintenance.

### 3.2.2 Belt

- Check front, back, and edges of belt for wear, rips, tears, holes, and dirt accumulation. Clean belt with detergent and water. Replace belt as required.
- Check belt tension under load. The belt should be just tight enough to prevent slipping at the drive pulley with a rated load. Loose belts cause excessive wear on the drive pulley lagging, and jerky load movement. Tight belts cause tears, lacing failure, and excessive motor power.
- Check belt lacing for broken, bent, loose, or missing clips and pins. Replace lacing as required.

### 3.2.3 Motor and Reducer

- Make sure the reducer is filled to the proper level with oil. Make sure breather hole is clean and the orifice is open.
- Inspect reducer for leaks.
- Use only oil recommended by the reducer manufacturer.

### 3.2.4 Rollers and Bearings

- Check drive pulley lagging for rips, tears, and missing areas. Replace pulley as required.
- Check all rollers and pulleys for tightness. All rollers must rotate freely. If roller does not turn freely check for dirt accumulation in bearing area and clean.
- Lubricate all flange type bearings that have grease fittings. Use NLGI Grade 2 Lithium base grease, Shell Alvania EP2, or equal. Snub roller and return roller bearings are not regreasable.
- Listen to bearing for excessive noise. Replace as required.

### 3.2.5 Conveyor Bed and Supports

- Check conveyor frame, splices, supports, and bearings for loose or missing hardware. Replace hardware as required.

### 3.2.6 Cleaning

- Periodically remove drive chains and clean by immersing in solvent and scrubbing with a wire brush. Rinse thoroughly and re-lubricate. Verify proper chain tension.
- Clean chain box and keep free of all debris.

## 3-3 REPLACEMENT PARTS

To order replacements parts, please contact your LEWCO distributor. If unable to contact distributor, please contact LEWCO's Customer Service Department by calling 419-625-4014, ext. 4012 or emailing [customerservice@lewcoinc.com](mailto:customerservice@lewcoinc.com). Please be prepared to provide both your MODEL and SERIAL NUMBER when ordering. Serial numbers can be found on unit labels. There is one unit label per each section of conveyor.

*LEWCO, Inc.*

**Serial No.:** 026563-001

**Model No.:** MDCS-12-120-60-36-36-B98-D08-G99-M99-A11-SCC10-P94

**Section No.:** 026563-001-01

## SECTION 5 – TROUBLESHOOTING

TROUBLE	CAUSE	SOLUTION
<b>Conveyor does not start or motor stalls.</b>	Motor overloaded	Check conveyor loading against design parameters.
	Motor drawing excessive current.	Check circuit breaker.
<b>Excessive wear on drive chain and/or sprockets.</b>	Lack of lubrication.	Lubricate chain.
	Sprockets out of alignment.	Align sprockets.
	Loose drive chain.	Correct chain slack (See "Pre Startup Checks").
<b>Loud popping and/or grinding noise.</b>	Defective bearing.	Replace bearing.
	Loose drive sprocket set screw.	Tighten sprocket set screws and check key.
	Loose drive chain.	Correct chain slack (See "Pre Startup Checks").
<b>Motor or reducer overheating. (Note: Many motors and reducers can be hot to the touch and still be operating within normal parameters.)</b>	Conveyor overloaded.	Check conveyor loading against design parameters.
	Low voltage to motor.	Correct voltage level as stated on motor name plate.
	Reducer lubricant level low.	Fill reducer reservoir.
<b>Drive pulley turns but belt does not move or moves with jerky motion.</b>	Conveyor overloaded.	Check conveyor loading against design parameters.
	Loose belt.	Tighten belt. (See belt tensioning and adjustment section.)
	Belt wrong side up.	Install belt right side up.
<b>Belt slips and squeals.</b>	Belt too loose, causing insufficient traction between belt and pulley.	Lag drive pulley with rough top belting; increase tension slightly.
<b>One part of belt creeps to one side.</b>	Belt ends at fasteners not cut square; fasteners not joined properly.	Use T-square to cut belt ends perfectly square; replace with the correct fasteners.
	Belt is bowed.	If belt is new, this condition should straighten out after belt is run under full load tension or is "broken in"; if not, belt must be replaced.
<b>Ply separation in belt carcass.</b>	Edge of belt worn or broken due to excessive rubbing.	Check alignment of conveyor frame, pulleys and idlers.
	Damage by abrasive, acid, heat chemicals, mildew, or oil.	Use a belt properly compounded to resist deterioration from acids, etc.
<b>Belt stretches excessively.</b>	Tension on belt too high.	Reduce tension roller to a point where belt will run without slipping; lag the drive pulley.
<b>Belt creeps to one side of tail pulley.</b>	Tail pulley or return idlers near the tail pulley are out of alignment (not perpendicular with centerline of conveyor).	Re-align by advancing (in the direction of the return belt travel) the end of the pulley or idler to which the belt has shifted.
<b>Belt creeps to one side of head pulley.</b>	Head pulley or idlers immediately preceding head pulley are out of alignment (not perpendicular with centerline of conveyor).	Re-align by advancing (in the direction of belt travel) the end of the pulley or idler to which the belt has shifted.
<b>Belt creeps to one side at one spot only on long conveyor.</b>	One or more idlers (usually immediately preceding the trouble spot) are out of alignment (not perpendicular with centerline of conveyor).	Advance (in direction of belt travel) the end of the idler to which the belt has shifted.
	Improper loading of belt.	Loading should be in direction of belt travel and centered on belt.
	Frozen idlers or idlers not properly located.	Lubricate idlers and improve maintenance; relocate improperly placed idlers and check alignment with a T-square.
	Conveyor frame or structure are crooked or not level which causes belt to shift to low side.	Check alignment by stretching a string along edge of frame and make correction; level structure.
	Foreign material build-up on pulleys or idlers.	Clean pulleys and idlers and improve maintenance by installing scrapers or other cleaning devices; check belt carcass for "bleeding".
	Pulleys (drive, tail, idlers or snubbers) out of alignment (not perpendicular with centerline of conveyor).	Re-check and square by using a T-square against edge of conveyor and pulleys of idler.