

Model: T02C25

### Chain Transfer, 1,500 LB. Capacity, 1" Lift, External

Chain Transfer Conveyors provide a method for right angle, directional changes within a Chain Driven Live Roller Conveyor (CDLR). Product conveys on the roller conveyor and when prompted, a pneumatic cylinder raises the chain up between the rollers and transfers product off the conveyor. This rugged design, capable of handling up to 1,500 lbs., is ideal for transferring pallets, containers, structural steel, and similar heavy loads. The "external" chain design is useful for transferring products that require minimal gaps in order to convey properly.

#### Chain Centers

- 15" to 48"

#### Number of Strands

- 2, 3, or 4

#### Conveyor Chain

- C60 chain guided by UHMW track.
- Optional:
  - Steel track

#### Effective Width

- 36" to 60"

#### Roller Centers

- 4.5" or 6"

#### Rollers

- 2.50" dia. x 11ga. mild steel tube with 11/16" hex axle, spring retained, with precision, greased packed ABEC bearings, and #60 sprockets.
- Optional:
  - Cotter pin retained axle
  - Galvanized roller tube
  - Polyurethane roller sleeve
  - Ultrex accumulation sleeves

#### Frame Construction

- 8ga. steel formed & welded.

#### Motor

- 3/4 HP
- Totally Enclosed Fan Cooled motor
- Optional:
  - Inverter Duty motor
  - Power Off Brake motor
- Voltage: 230/460/ 3Ph/ 60hz
- Optional:
  - 115V/ 1Ph/ 60Hz
  - 208V/ 1Ph/ 60Hz
  - 230V/ 1Ph/ 60Hz
  - 575V/ 3Ph/ 60Hz
  - 24VDC

#### Speed

- 10 to 50 FPM (feet per minute)
- Reverse capability optional

#### Control Options

- Variable Speed Controller
- Combination motor starter with disconnect, fixed speed
- Combination motor starter with disconnect, variable speed
- PLC with HMI
- No controls (provided by others)

#### Air Requirements

- Transfer lift is pneumatically actuated. Requires approx. 0.10 Ft<sup>3</sup> of 60 PSI air per lift cycle. Includes Filter-Regulator-Lubricator and (2) position double solenoid valve, 120-volt or 24-volt DC coils.

#### Conveyor Color

- Blue (RAL 5017)
- Guards are yellow (RAL 1023)
- Moving parts are bright red orange (RAL 2008).
- Optional:
  - Light Gray (RAL 7035)
  - Repose Gray (not an RAL)
  - Patina Green (RAL 6000)
  - Signal White (RAL 9003)
  - Jet Black (RAL 9005)
  - Flat Black (not an RAL)
  - Custom colors available

#### Additional Options

- Conveyor Supports
- Guardrail
- End Stop
- Fork Truck Barriers
- Photo Eye Sensor(s)
- Custom sizes and features available. Please consult a LEWCO Applications Engineer for more information.

#### Quality Assurance

- Each unit comes complete with a (1) year warranty and is tested prior to shipment.
- Manufactured under ISO 9001 Quality Certified System.

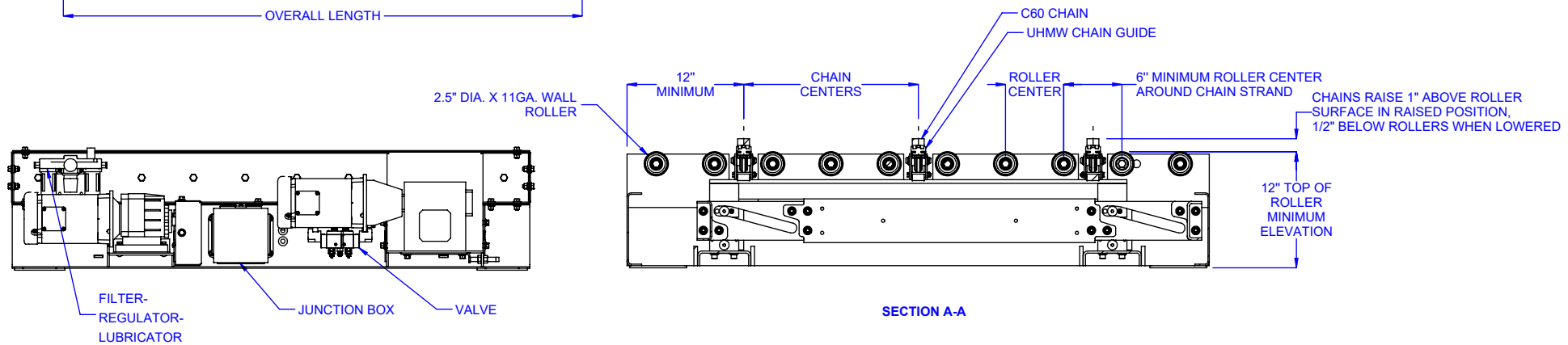
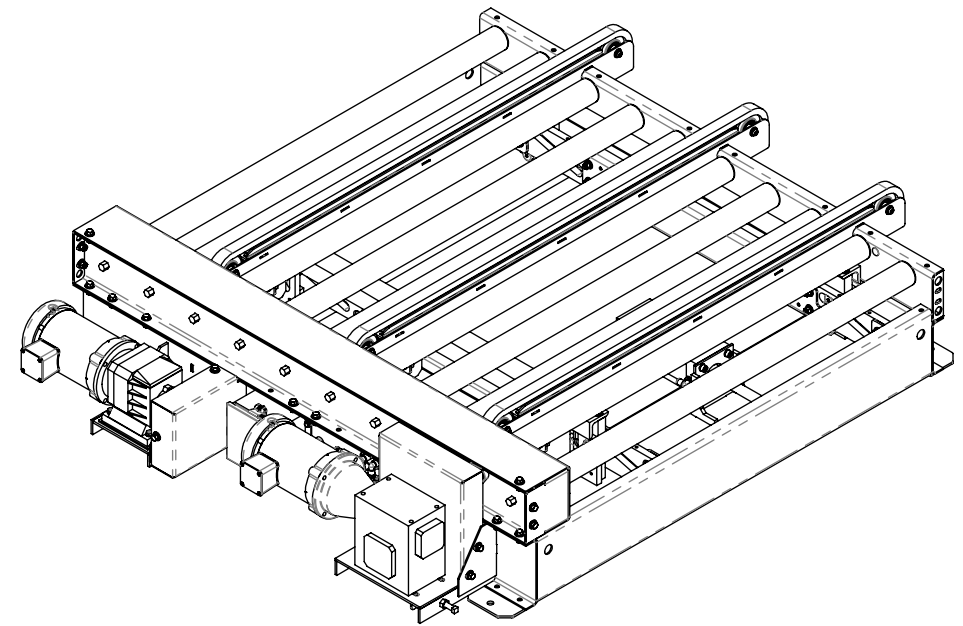
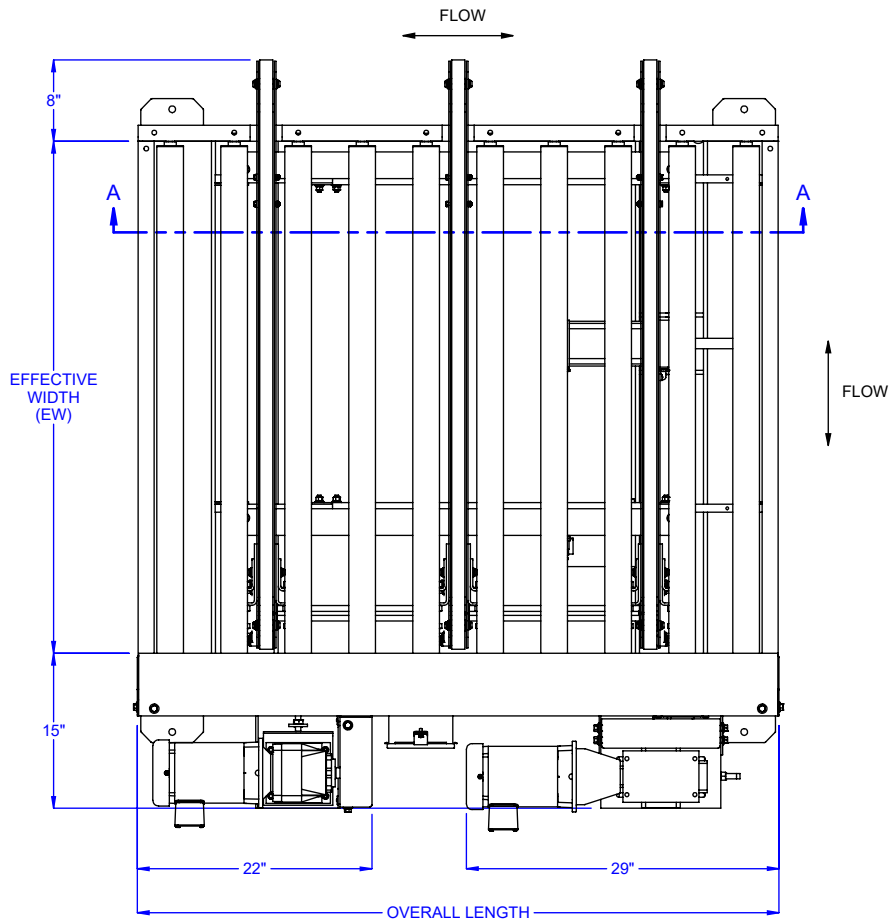

MODEL: T02C25  
 DESCRIPTION: CHAIN TRANSFER, 1500 LB. CAPACITY, EXTERNAL DESIGN WITH CDLR25 CONVEYOR

LEWCO, INC. IS COMMITTED TO CONTINUOUS IMPROVEMENT AND RESERVES THE RIGHT TO CHANGE DESIGNS AND SPECIFICATIONS WITHOUT NOTICE.

THIS DRAWING MUST NOT BE COPIED, REPRODUCED OR USED FOR ANY PURPOSE WITHOUT THE WRITTEN CONSENT OF LEWCO, INC. ALL RIGHTS RESERVED.



706 LANE ST. SANDUSKY, OH 44870, U.S.A.

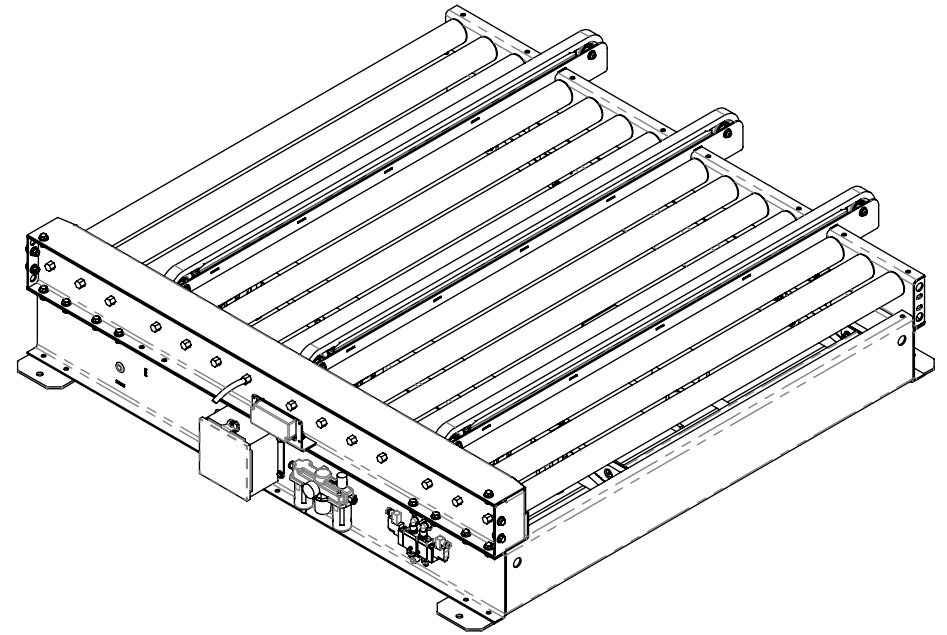
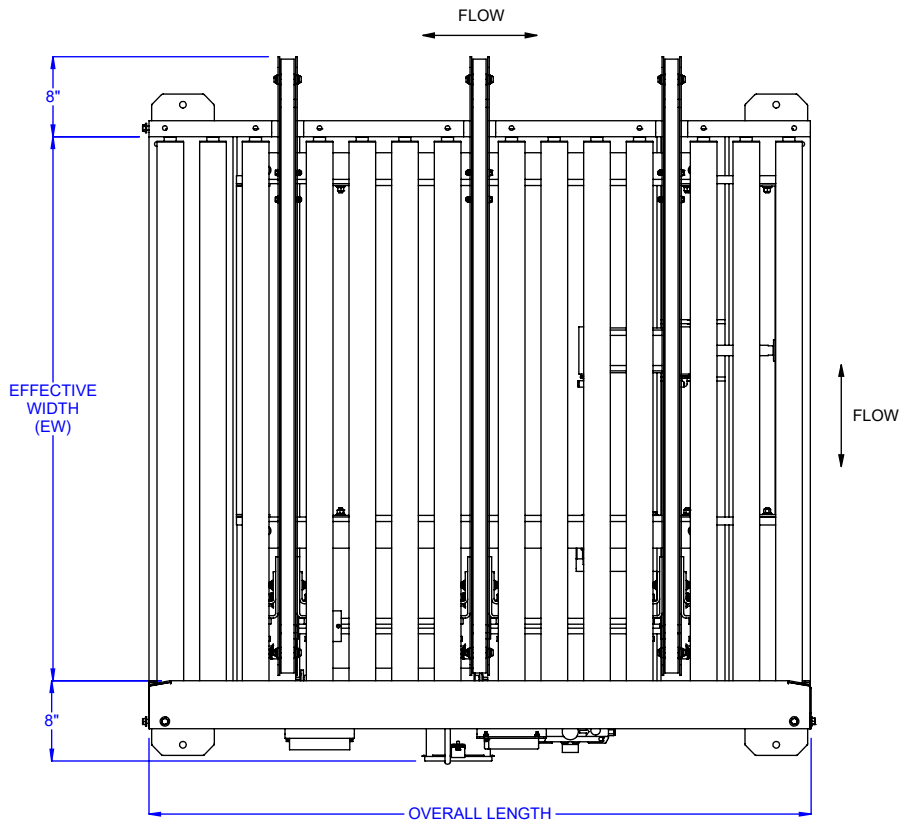

**24 VDC OPTION**

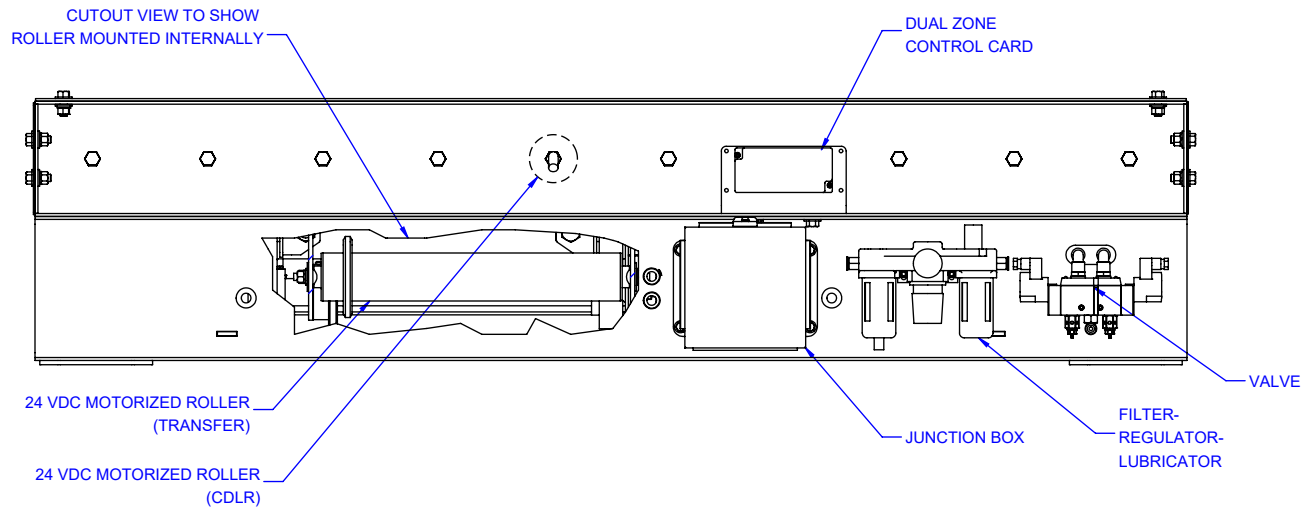

**MODEL:** T02C25

**DESCRIPTION:** CHAIN TRANSFER, 1500 LB. CAPACITY, EXTERNAL DESIGN WITH CDLR CONVEYOR

LEWCO, INC. IS COMMITTED TO CONTINUOUS IMPROVEMENT AND RESERVES THE RIGHT TO CHANGE DESIGNS AND SPECIFICATIONS WITHOUT NOTICE.

THIS DRAWING MUST NOT BE COPIED, REPRODUCED OR USED FOR ANY PURPOSE WITHOUT THE WRITTEN CONSENT OF LEWCO, INC. ALL RIGHTS RESERVED.



706 LANE ST. SANDUSKY, OH 44870, U.S.A.

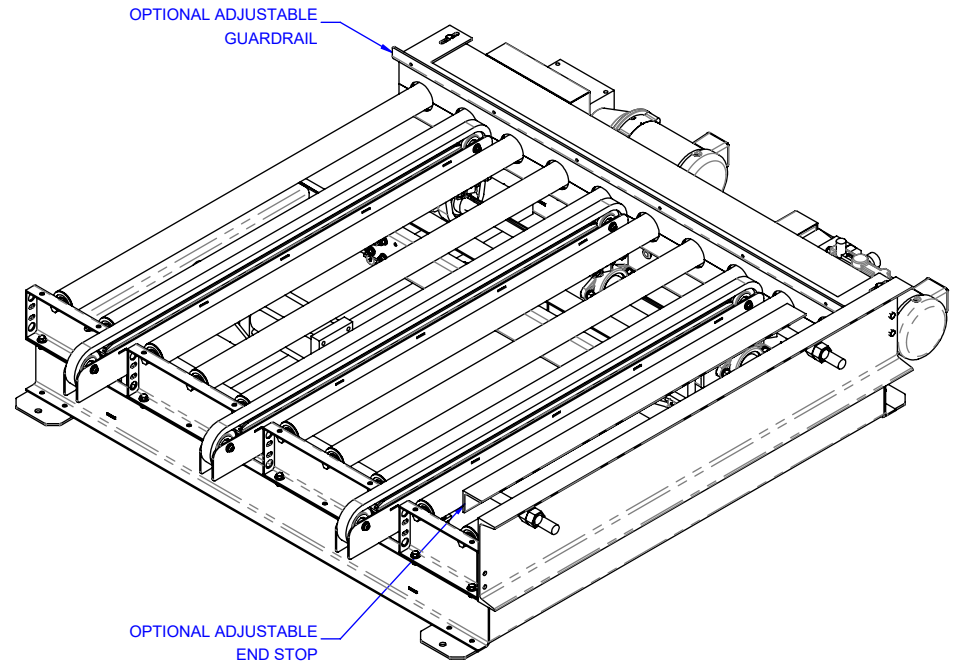
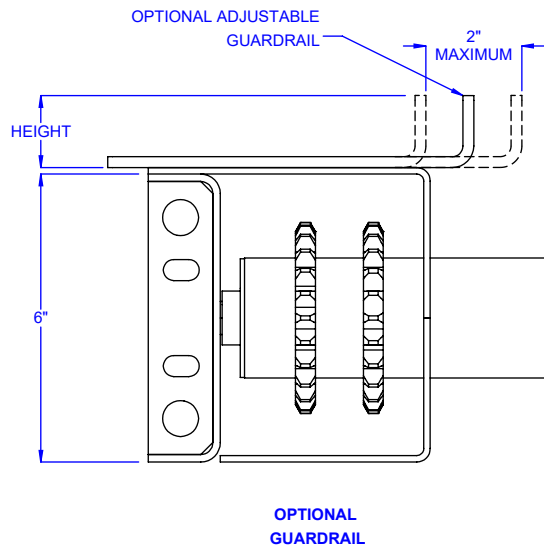

### GUARDRAIL AND END STOP OPTIONS

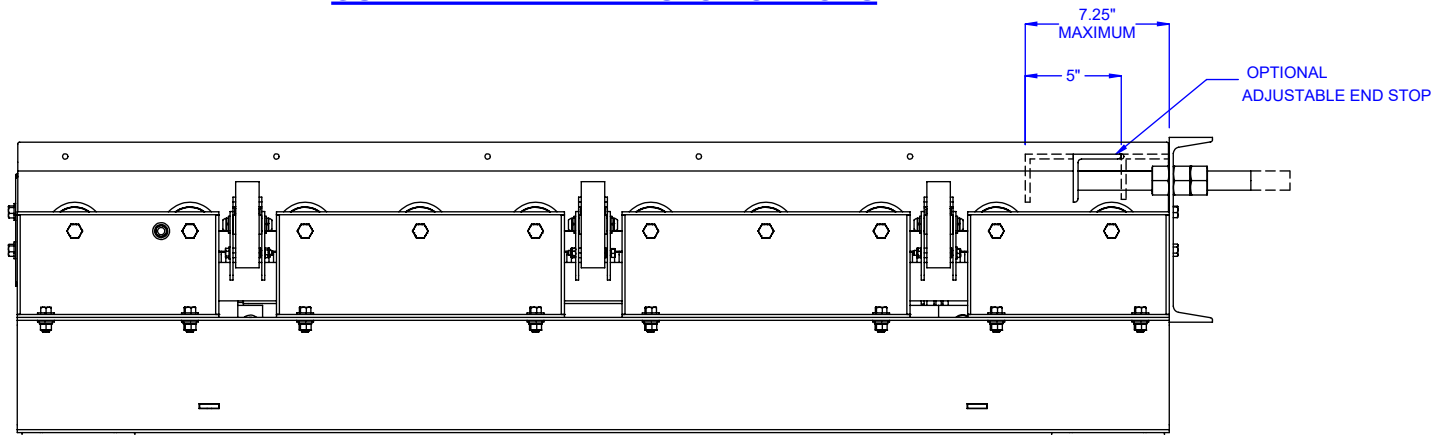

**MODEL:** T02C25

**DESCRIPTION:** CHAIN TRANSFER, 1500 LB. CAPACITY, EXTERNAL DESIGN WITH CDLR25 CONVEYOR

LEWCO, INC. IS COMMITTED TO CONTINUOUS IMPROVEMENT AND RESERVES THE RIGHT TO CHANGE DESIGNS AND SPECIFICATIONS WITHOUT NOTICE.

THIS DRAWING MUST NOT BE COPIED, REPRODUCED OR USED FOR ANY PURPOSE WITHOUT THE WRITTEN CONSENT OF LEWCO, INC. ALL RIGHTS RESERVED.



706 LANE ST. SANDUSKY, OH 44870, U.S.A.