



Model: CDLR19

Chain Driven Live Roller Conveyor, 1.9" dia.

Chain driven roller conveyor is the workhorse of heavy-duty material handling and is an excellent choice for moving pallets and other moderate weight loads. Its rugged bolted frame construction makes it a great solution for harsh environments. Chain driven roller conveyor also provides versatility in production lines because it can easily incorporate with chain transfers, turntables, and curves.

Effective Width

- 6" to 48"

Length

- 36" to 600"

Roller Centers

- 4", 6", 8", or 12"

Rollers

- 1.90" dia. x 12ga. mild steel tube with 7/16" hex axle, spring retained, with precision, greased packed ABEC bearings, and #40 sprockets.
- Optional:
 - 9ga. mild steel tube
 - Cotter pin retained axle
 - Galvanized roller tube
 - Polyurethane roller sleeve
 - Ultrex accumulation sleeves

Frame Construction

- Formed 8ga. channel, 5" on chain box side & 3-1/2" opposite side with rollers set 1/4" high
- Optional:
 - Formed 6"x8ga. channel with rollers set 1-1/4" low
 - Structural channel, 5"x6.7# with rollers set low

Drive Location

- Standard drive is mounted high near center of conveyor length on chain box side.
- Optional:
 - Drive mounted low or drive mounted below and within frame, near center.

Motor

- 1/2 HP to 2 HP
- Totally Enclosed Fan Cooled motor
- Optional:
 - Inverter Duty motor
 - Power Off Brake motor
- Voltage: 230/460/ 3Ph/ 60hz
- Optional:
 - 115V/ 1Ph/ 60Hz
 - 208V/ 1Ph/ 60Hz
 - 230V/ 1Ph/ 60Hz
 - 575V/ 3Ph/ 60Hz
 - 24VDC

Speed

- 10 to 100 FPM (feet per minute)

Control Options

- Variable Speed Controller
- Combination motor starter with disconnect, fixed speed
- Combination motor starter with disconnect, variable speed
- PLC with HMI
- No controls (provided by others)

Conveyor Color

- Blue (RAL 5017)
- Guards are yellow (RAL 1023)
- Moving parts are bright red orange (RAL 2008).
- Optional:
 - Light Gray (RAL 7035)
 - Repose Gray (not an RAL)
 - Patina Green (RAL 6000)
 - Signal White (RAL 9003)
 - Jet Black (RAL 9005)
 - Flat Black (not an RAL)
 - Custom colors available

Additional Options

- Conveyor Supports
- Guardrail
- Fork Truck Barriers
- Photo Eye Sensor(s)
- Custom sizes and features available. Please consult a LEWCO Applications Engineer for more information.

Quality Assurance

- Each unit comes complete with a (1) year warranty and is tested prior to shipment.
- Manufactured under ISO 9001 Quality Certified System.

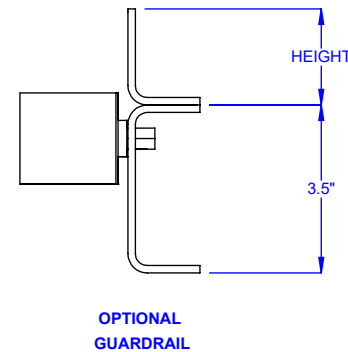
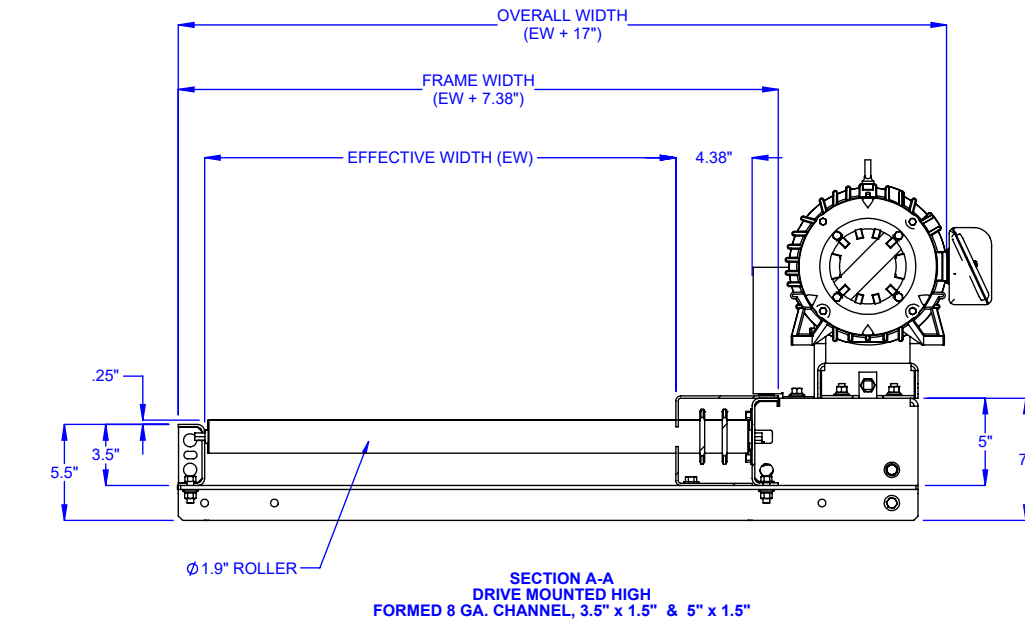
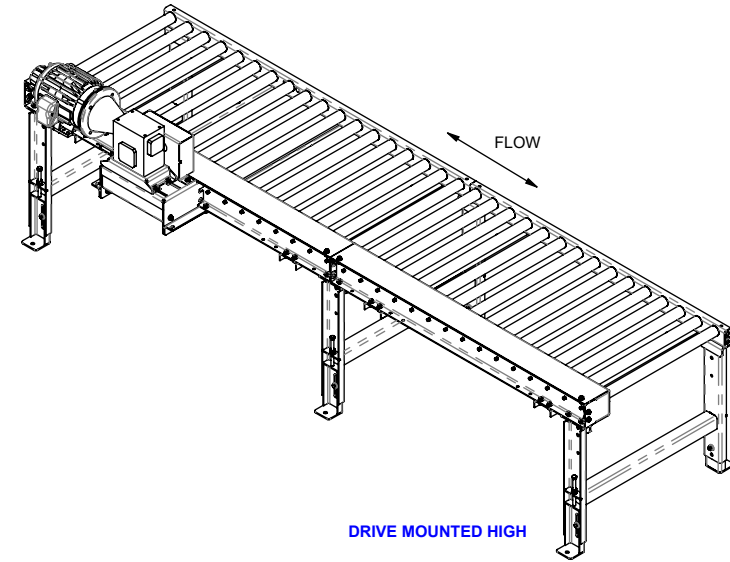
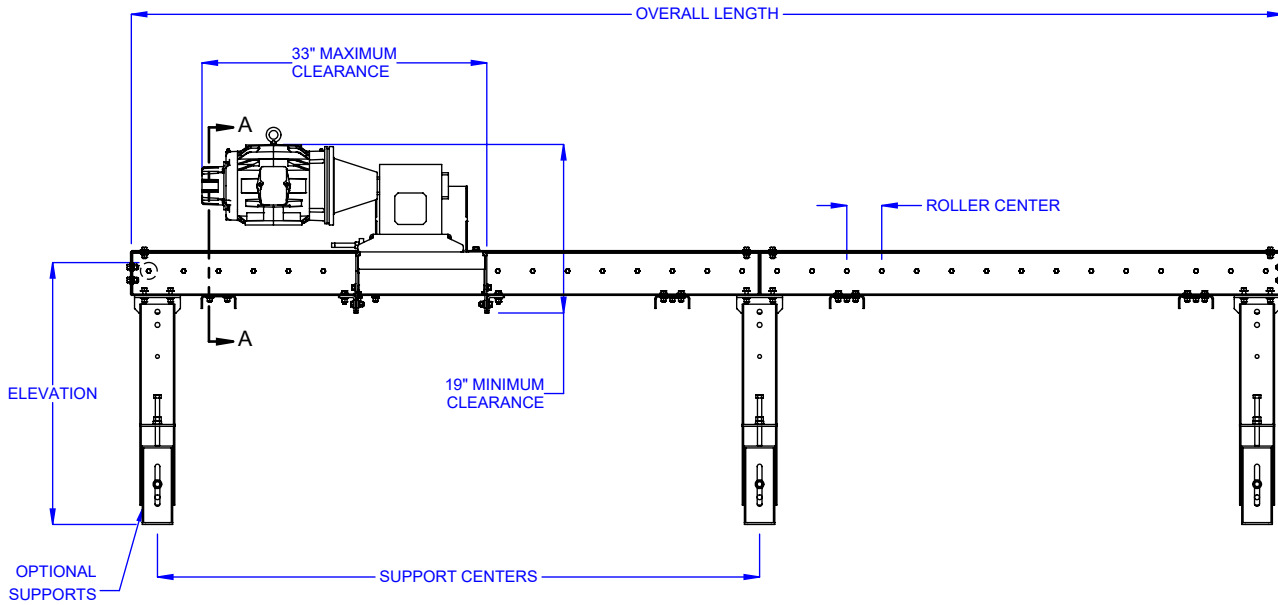

LOAD CAPACITY @ 60 FPM (LBS) 4" ROLLER CENTERS, 20 FT LENGTH			
HP	WIDTH		
	12"	30"	48"
1/2	1550	1350	1150
3/4	2450	2250	2100
1	3350	3150	3000
1 1/2	5150	4950	4800
2	7500	7500	7500

LOAD CAPACITY @ 30 FPM (LBS) 4" ROLLER CENTERS, 20 FT LENGTH			
HP	WIDTH		
	12"	30"	48"
1/2	3350	3150	3000
3/4	5150	4950	4800
1	7500	7500	7500
1 1/2	7500	7500	7500
2	7500	7500	7500

MAXIMUM UNIT LOAD PER LINEAR FOOT OF CONVEYOR IS 150 POUNDS - NOT TO EXCEED CAPACITY ABOVE

* HP requirements will vary for different drive options and conveyor lengths, roller centers, pallet types and chain lubrication conditions. Consult factory.

MODEL: CDLR19

DESCRIPTION: CHAIN DRIVEN LIVE ROLLER CONVEYOR

LEWCO, INC. IS COMMITTED TO CONTINUOUS IMPROVEMENT AND RESERVES THE RIGHT TO CHANGE DESIGNS AND SPECIFICATIONS WITHOUT NOTICE.

THIS DRAWING MUST NOT BE COPIED, REPRODUCED OR USED FOR ANY PURPOSE WITHOUT THE WRITTEN CONSENT OF LEWCO, INC. ALL RIGHTS RESERVED.



706 LANE ST. SANDUSKY, OH 44870, U.S.A.

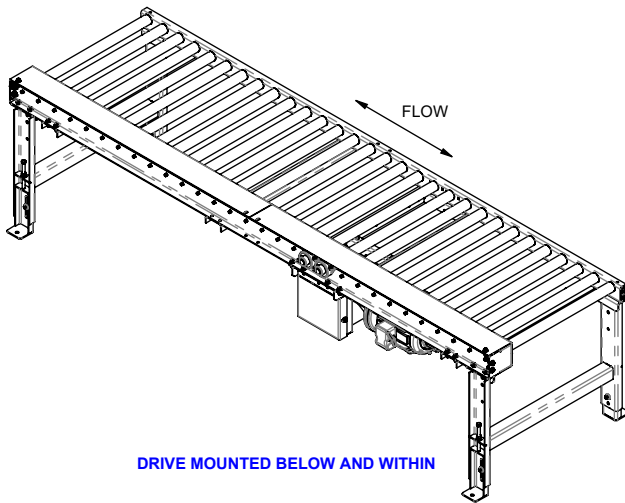

DRIVE MOUNTED BELOW AND WITHIN

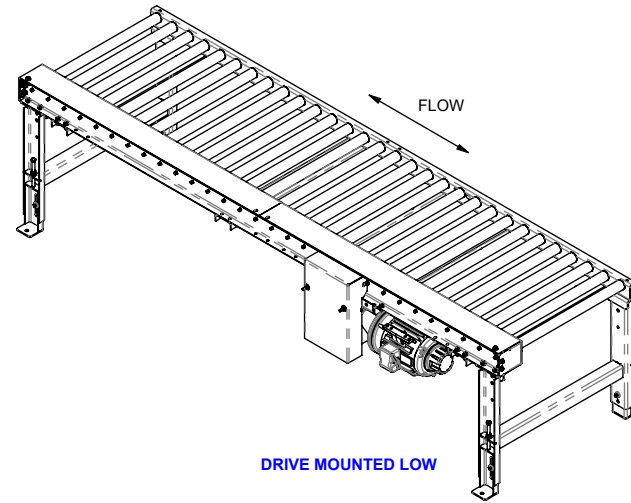

DRIVE MOUNTED LOW

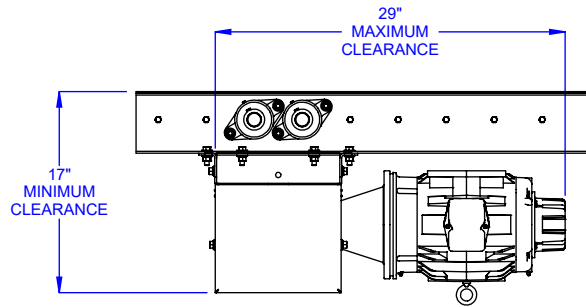

DRIVE MOUNTED
BELOW AND WITHIN
OPTION

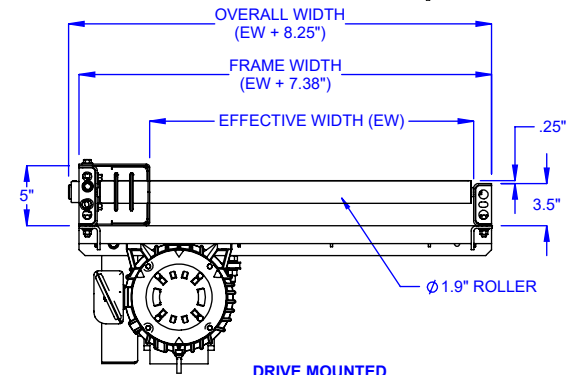

DRIVE MOUNTED
BELOW AND WITHIN
END VIEW

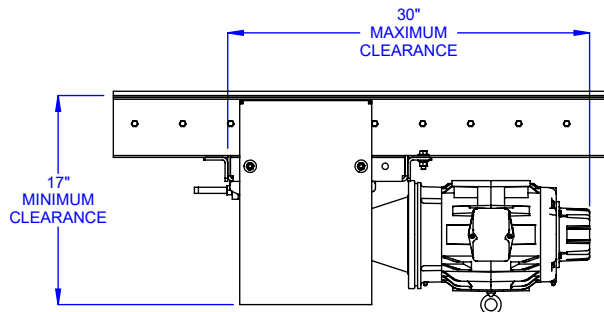

DRIVE MOUNTED LOW
OPTION

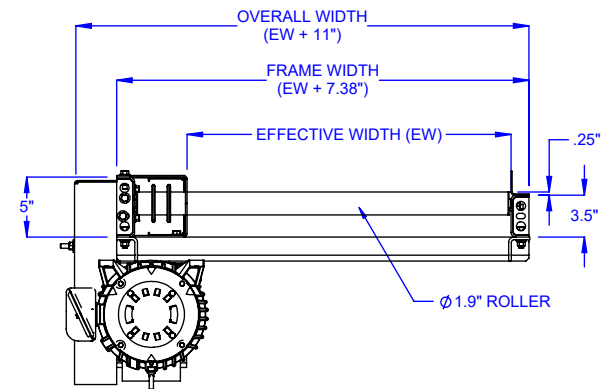

DRIVE MOUNTED LOW
END VIEW

MODEL: CDLR19

DESCRIPTION: CHAIN DRIVEN LIVE ROLLER CONVEYOR

LEWCO, INC. IS COMMITTED TO CONTINUOUS IMPROVEMENT AND RESERVES THE RIGHT TO CHANGE DESIGNS AND SPECIFICATIONS WITHOUT NOTICE.

THIS DRAWING MUST NOT BE COPIED, REPRODUCED OR USED FOR ANY PURPOSE WITHOUT THE WRITTEN CONSENT OF LEWCO, INC. ALL RIGHTS RESERVED.

LEWCO

706 LANE ST. SANDUSKY, OH 44870, U.S.A.

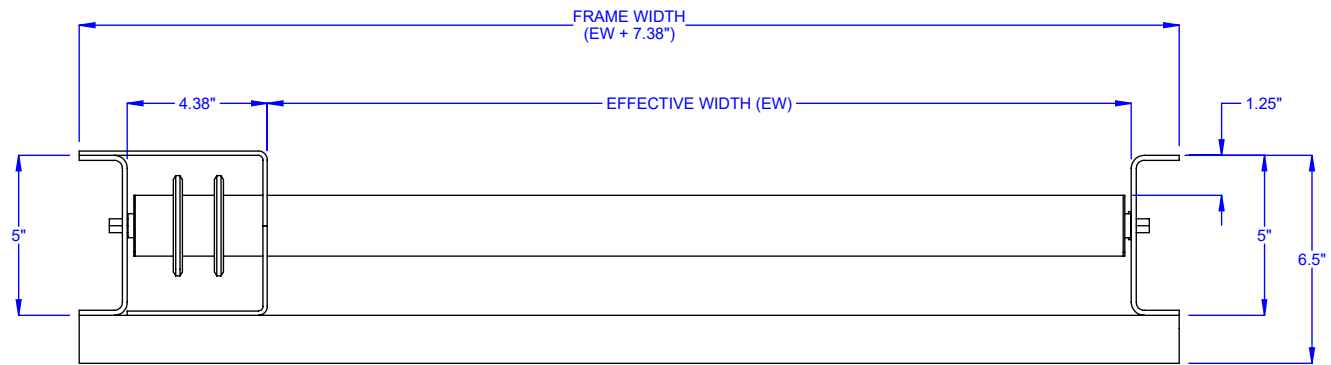

OPTIONAL FRAME
FORMED 8 GA. CHANNEL, 5" x 1-1/2"

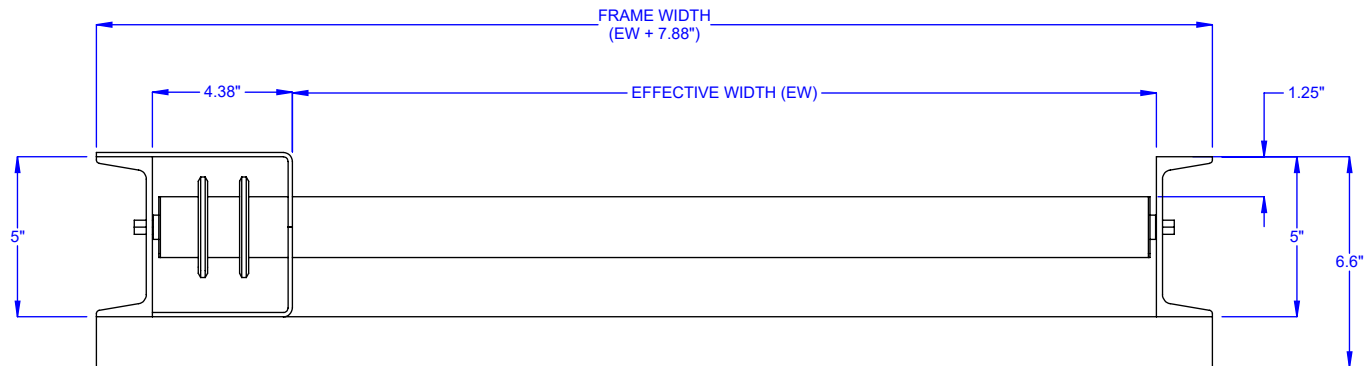

OPTIONAL FRAME
STRUCTURAL CHANNEL, 5" x 6.7#

MODEL: CDLR19

DESCRIPTION: CHAIN DRIVEN LIVE ROLLER CONVEYOR

LEWCO, INC. IS COMMITTED TO CONTINUOUS
 IMPROVEMENT AND RESERVES THE RIGHT TO CHANGE
 DESIGNS AND SPECIFICATIONS WITHOUT NOTICE.

THIS DRAWING MUST NOT BE COPIED, REPRODUCED
 OR USED FOR ANY PURPOSE WITHOUT THE WRITTEN
 CONSENT OF LEWCO, INC. ALL RIGHTS RESERVED.



706 LANE ST. SANDUSKY, OH 44870, U.S.A.