

MDRB – Medium Duty Roller Bed with 1.90” Diameter Rollers

Model MDRB is a medium duty, roller bed belt conveyor designed for wide applications. These conveyors are capable of moving heavier loads with less power than typical slider bed belt conveyors.

Belt Width

- 12”, 18”, 24”, 30”, 36”, 42”, 48”

Length

- 60” to 1,200”

Belt

- PVC120 EMB embossed cover with clipper lacing.
- Optional:
 - PVC120 smooth top
 - PVC150 rough top
 - PVC120, Black, friction both sides
 - PVC Food grade, White
 - Thermoplastic polyurethane (TPU) Covered Belt
 - PVC longitudinal groove
 - No Belt
- Troughed Belts design also available.

Drive Location

- End Drive, Bottom Right
- Optional:
 - End Drive, Bottom, Left
 - End Drive, Side, Right or Left
 - Center Drive, Right or Left (standard for conveyors with reverse)

Motor

- 1/2 HP to 2 HP
- Totally Enclosed Fan Cooled motor
- Optional:
 - Inverter Duty motor
 - Power Off Brake motor
- Voltage: 230/460/ 3Ph/ 60hz
- Optional:
 - 115V/ 1Ph/ 60Hz
 - 208V/ 1Ph/ 60Hz
 - 230V/ 1Ph/ 60Hz
 - 575V/ 3Ph/ 60Hz
 - 90V DC

Speed

- 15 to 300 FPM (feet per minute)
- Reverse capability optional

Control Options

- No controls (provided by others)
- Variable Speed Controller
- Combination motor starter with disconnect, fixed speed
- Combination motor starter with disconnect, variable speed
- PLC with HMI

Conveyor Color

- Blue (RAL 5017)
- Guards are yellow (RAL 1023)
- Moving parts are bright red orange (RAL 2008).
- Optional:
 - Light Gray (RAL 7035)
 - Repose Gray (not an RAL)
 - Patina Green (RAL 6000)
 - Signal White (RAL 9003)
 - Jet Black (RAL 9005)
 - Flat Black (not an RAL)
 - Custom colors available

Additional Options

- Conveyor Supports with or without casters
- Guardrail
- Photo Eye Sensor(s)
- Custom sizes and features available. Please consult a LEWCO Applications Engineer for more information.

Quality Assurance

- Each unit comes complete with a (1) year warranty.
- Manufactured under ISO 9001 Quality Certified System.

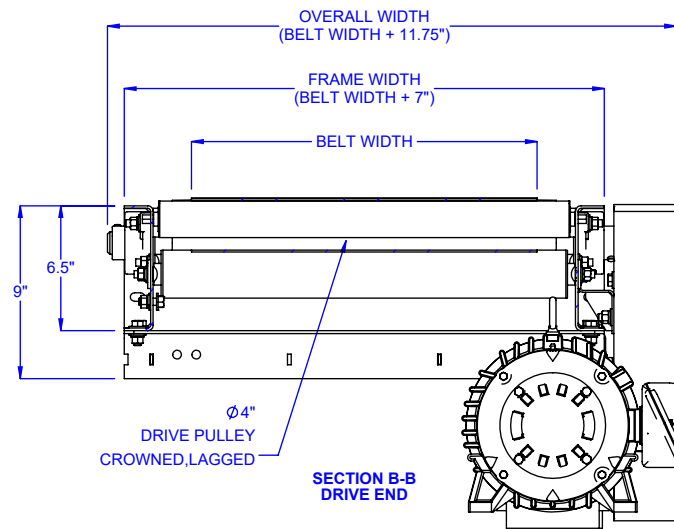
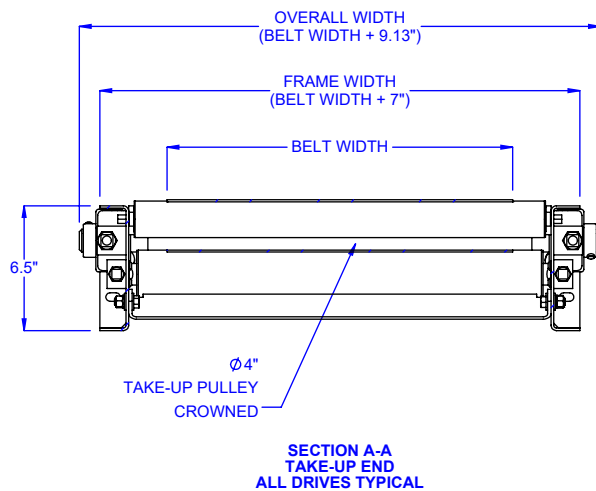
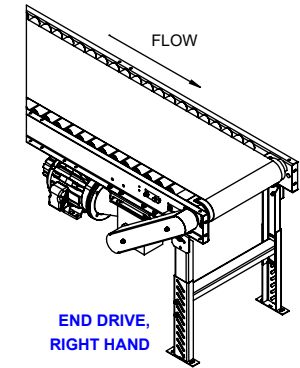
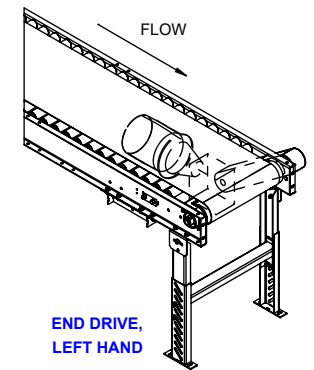
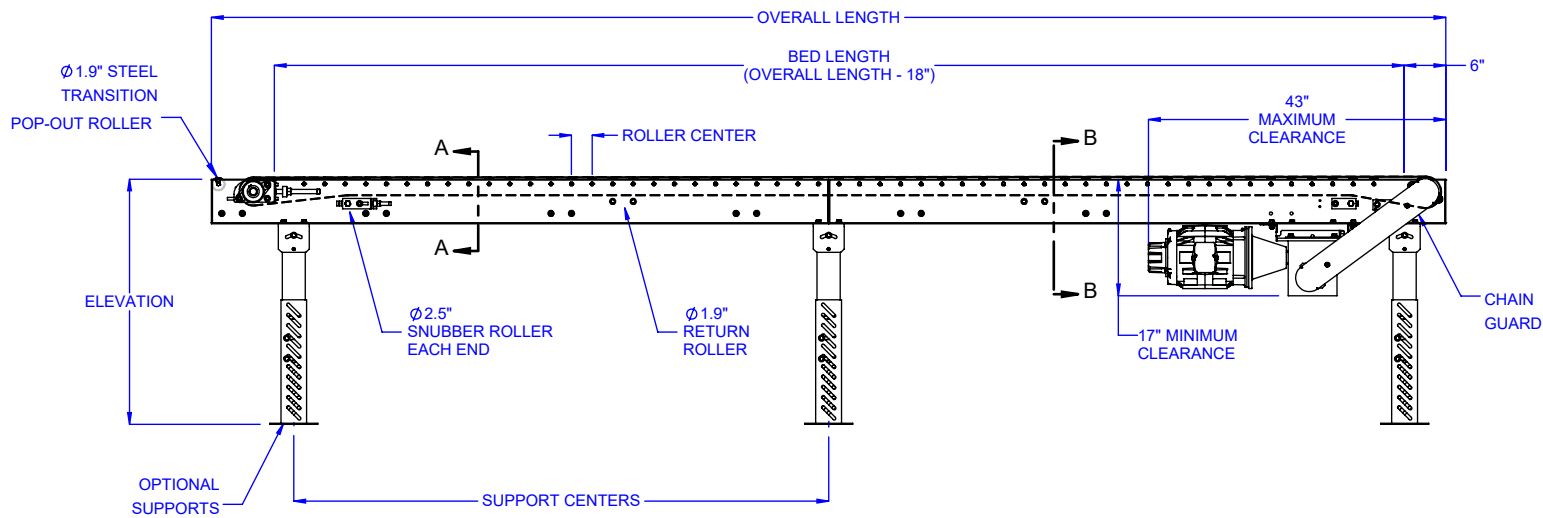

LOAD CAPACITY @ 60 FPM (LBS)							
HP	WIDTH						
	12"	18"	24"	30"	36"	42"	48"
1/2	725	690	660	625	590	560	525
3/4	1135	1100	1065	1135	1000	965	935
1	1540	1510	1475	1445	1410	1375	1345
1 1/2	2360	2325	2295	2260	2225	2195	2160
2	3175	3145	3110	3080	3045	3010	2980
LOAD CAPACITY @ 30 FPM (LBS)							
HP	WIDTH						
	12"	18"	24"	30"	36"	42"	48"
1/2	1550	1515	1485	1450	1415	1385	1350
3/4	2370	2335	2300	2270	2235	2200	2170
1	3185	3150	3120	3085	3050	3020	2985
1 1/2	-	4785	4755	4720	4685	4655	4620
2	-	-	6390	6355	6320	6290	6255
MAXIMUM LOAD PER LINEAR FOOT OF CONVEYOR IS 225 POUNDS - NOT TO EXCEED CAPACITY ABOVE							

* HP requirement may be slightly higher for closer roll centers

MODEL: MDRB
 DESCRIPTION: MEDIUM DUTY ROLLER BED BELT CONVEYOR

LEWCO, INC. IS COMMITTED TO CONTINUOUS IMPROVEMENT AND RESERVES THE RIGHT TO CHANGE DESIGNS AND SPECIFICATIONS WITHOUT NOTICE.

THIS DRAWING MUST NOT BE COPIED, REPRODUCED OR USED FOR ANY PURPOSE WITHOUT THE WRITTEN CONSENT OF LEWCO, INC. ALL RIGHTS RESERVED.

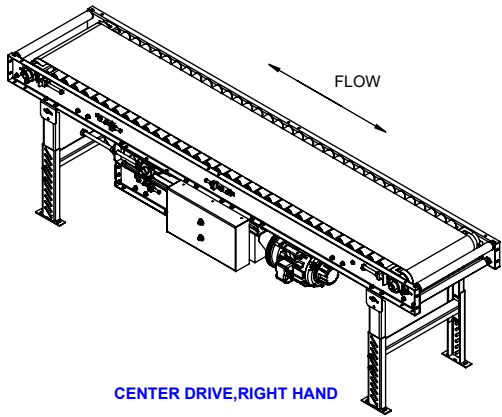

CENTER DRIVE, RIGHT HAND

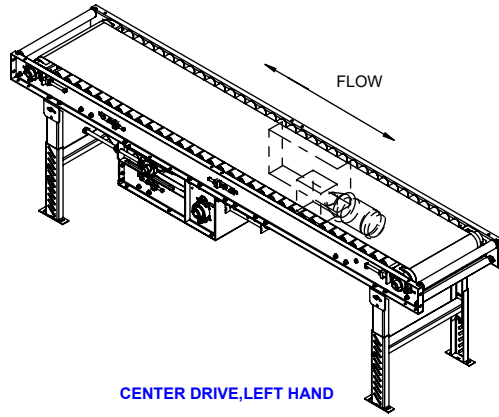

CENTER DRIVE, LEFT HAND

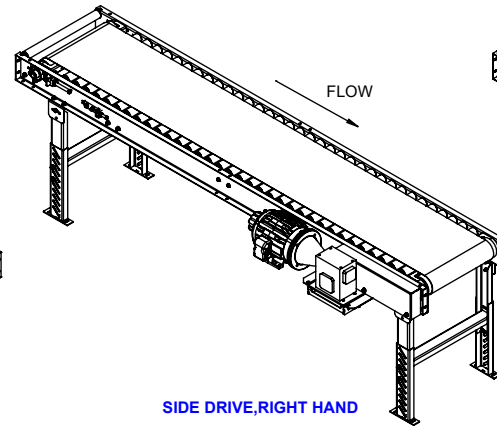

SIDE DRIVE, RIGHT HAND

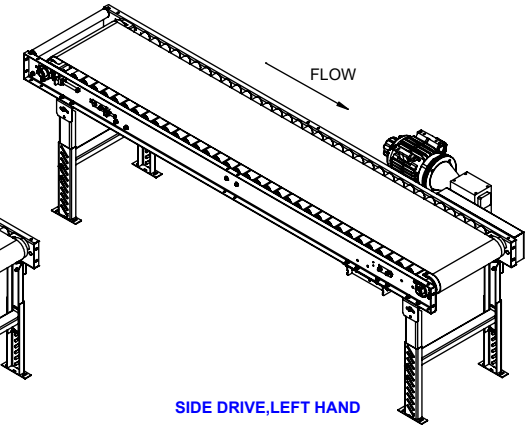

SIDE DRIVE, LEFT HAND

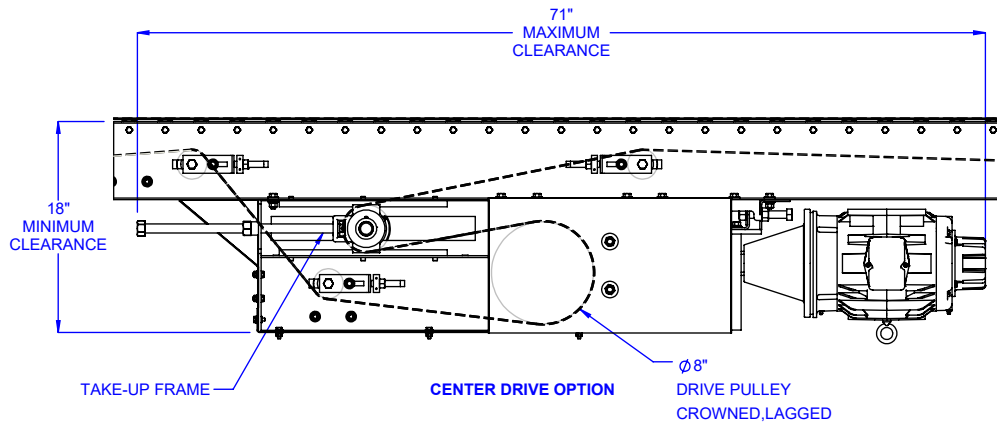

CENTER DRIVE OPTION

Ø8" DRIVE PULLEY
CROWNED, LAGGED

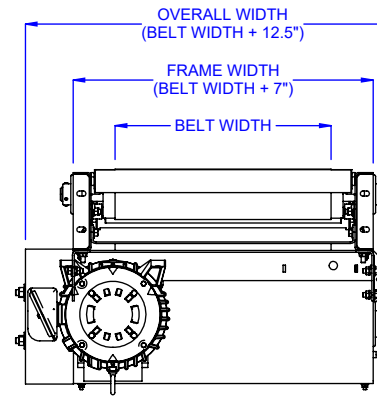

CENTER DRIVE
END VIEW

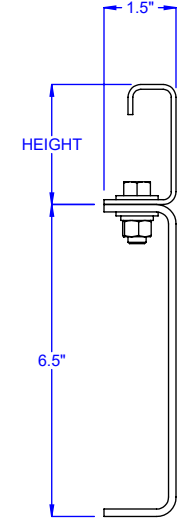

OPTIONAL
GUARDRAIL

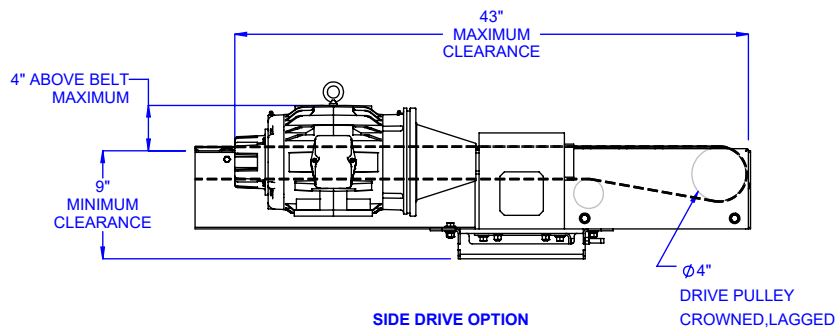

SIDE DRIVE OPTION

Ø4" DRIVE PULLEY
CROWNED, LAGGED

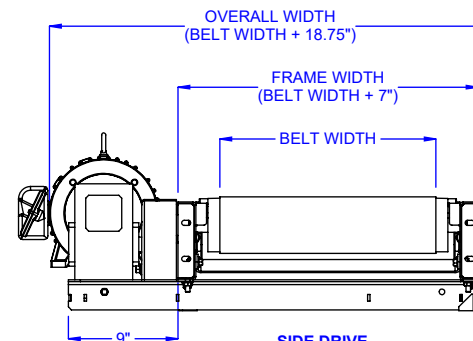

SIDE DRIVE
END VIEW

MODEL: MDRB
DESCRIPTION: MEDIUM DUTY ROLLER BED BELT CONVEYOR

LEWCO, INC. IS COMMITTED TO CONTINUOUS IMPROVEMENT AND RESERVES THE RIGHT TO CHANGE DESIGNS AND SPECIFICATIONS WITHOUT NOTICE.

THIS DRAWING MUST NOT BE COPIED, REPRODUCED OR USED FOR ANY PURPOSE WITHOUT THE WRITTEN CONSENT OF LEWCO, INC. ALL RIGHTS RESERVED.

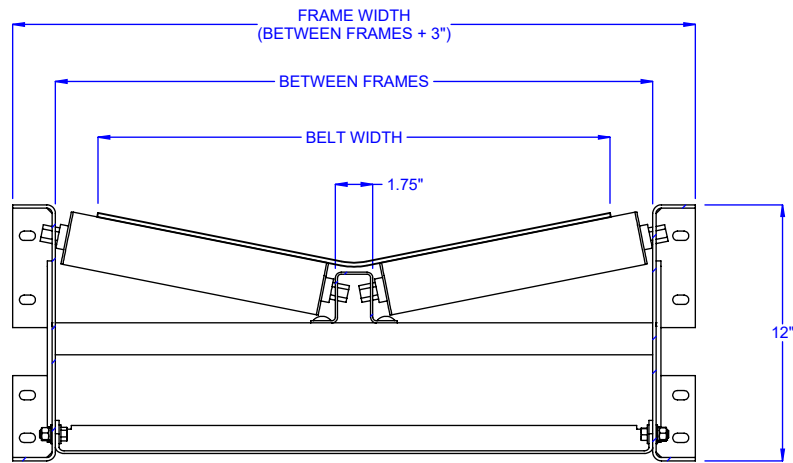

SECTION C-C

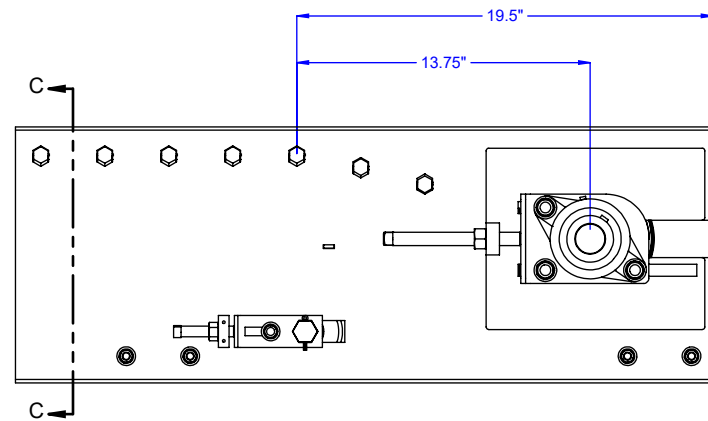

OPTIONAL TROUGH CONSTRUCTION

MODEL: MDRB

DESCRIPTION: MEDIUM DUTY ROLLER BED BELT CONVEYOR

LEWCO, INC. IS COMMITTED TO CONTINUOUS IMPROVEMENT AND RESERVES THE RIGHT TO CHANGE DESIGNS AND SPECIFICATIONS WITHOUT NOTICE.

THIS DRAWING MUST NOT BE COPIED, REPRODUCED OR USED FOR ANY PURPOSE WITHOUT THE WRITTEN CONSENT OF LEWCO, INC. ALL RIGHTS RESERVED.



706 LANE ST. SANDUSKY, OH 44870, U.S.A.