

## MDCS – Medium Duty, Channel Frame Slider Bed

Model MDCS is a medium duty, channel frame slider bed belt conveyor. The channel frame style makes it ideal for mounting sensors and other devices. These conveyors are used to provide a reliable way of transporting products in assembly, sorting, testing, and packaging applications.

### Belt Width

- 12", 18", 24", 30", 36", 42", 48"

### Length

- 48" to 1,200"

### Belt

- PVC120 EMB embossed cover with clipper lacing.
- Optional:
  - PVC120 smooth top
  - PVC150 rough top
  - PVC120, Black, friction both sides
  - PVC Food grade, White
  - Thermoplastic polyurethane (TPU) Covered Belt
  - PVC longitudinal groove
  - No Belt
- V-Guided Belt design also available.

### Drive Location

- End Drive, Bottom Right
- Optional:
  - End Drive, Bottom, Left
  - End Drive, Side, Right or Left
  - Center Drive, Right or Left (standard for conveyors with reverse)

### Motor

- 1/2 HP to 2 HP
- Totally Enclosed Fan Cooled motor
- Optional:
  - Inverter Duty motor
  - Power Off Brake motor
- Voltage: 230/460/ 3Ph/ 60hz
- Optional:
  - 115V/ 1Ph/ 60Hz
  - 208V/ 1Ph/ 60Hz
  - 230V/ 1Ph/ 60Hz
  - 575V/ 3Ph/ 60Hz
  - 90V DC

### Speed

- 15 to 300 FPM (feet per minute)
- Reverse capability optional

### Control Options

- No controls (provided by others)
- Variable Speed Controller
- Combination motor starter with disconnect, fixed speed
- Combination motor starter with disconnect, variable speed
- PLC with HMI

### Conveyor Color

- Blue (RAL 5017)
- Guards are yellow (RAL 1023)
- Moving parts are bright red orange (RAL 2008).
- Optional:
  - Light Gray (RAL 7035)
  - Repose Gray (not an RAL)
  - Patina Green (RAL 6000)
  - Signal White (RAL 9003)
  - Jet Black (RAL 9005)
  - Flat Black (not an RAL)
  - Custom colors available

### Additional Options

- Conveyor Supports with or without casters
- Guardrail
- Photo Eye Sensor(s)
- Custom sizes and features available. Please consult a LEWCO Applications Engineer for more information.

### Quality Assurance

- Each unit comes complete with a (1) year warranty.
- Manufactured under ISO 9001 Quality Certified System.

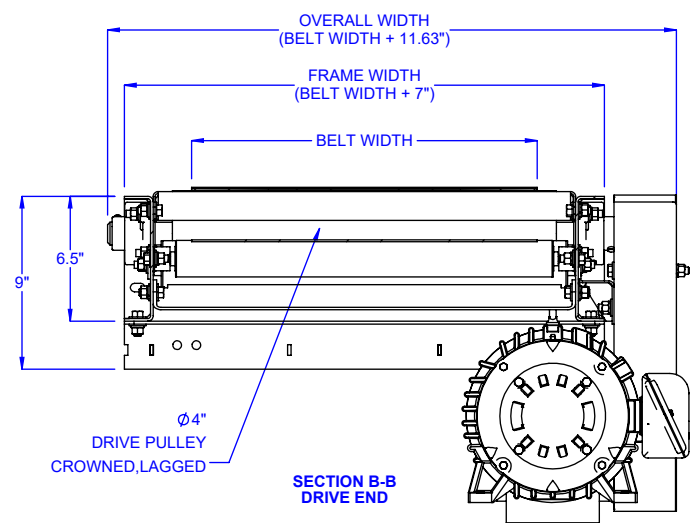
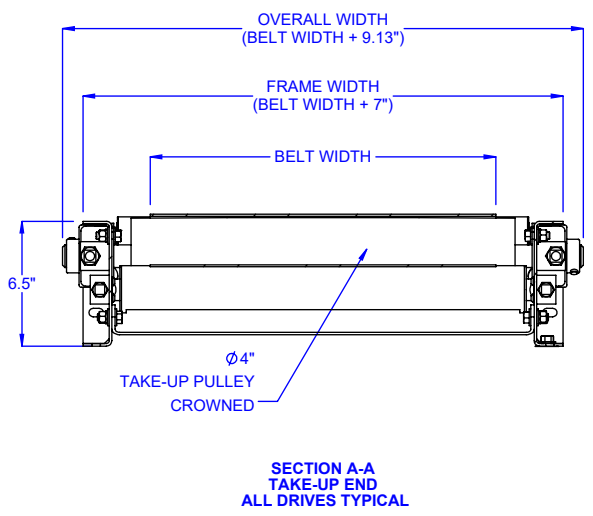
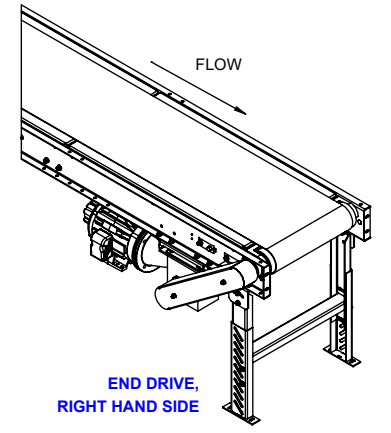
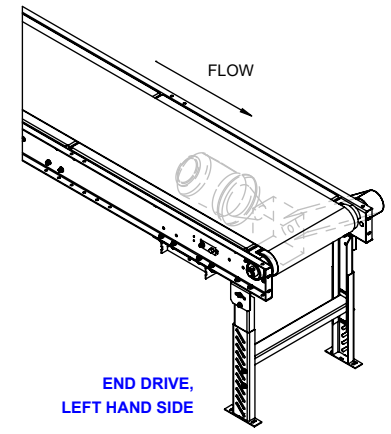
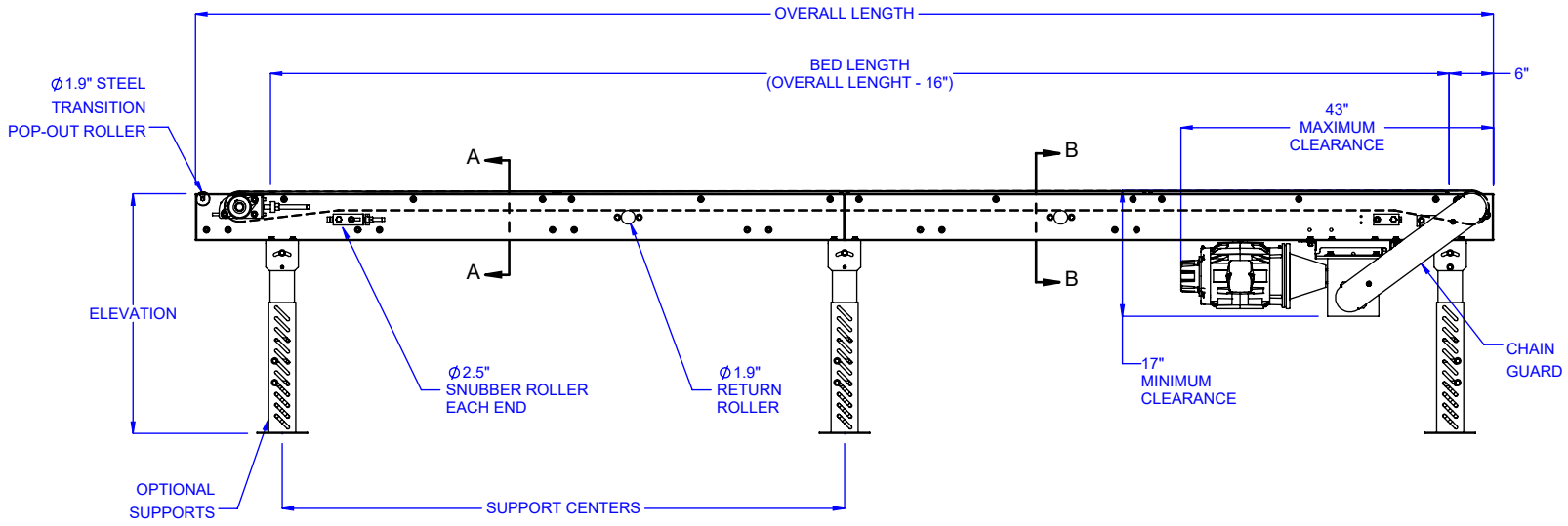

LOAD CAPACITY @ 60 FPM (LBS)								
HP	WIDTH							
	12"	18"	24"	30"	36"	42"	48"	
1/2	290	285	280	270	265	260	250	
3/4	445	440	435	425	420	410	405	
1	600	590	585	580	570	565	560	
1 1/2	905	895	890	885	880	870	865	
2	1210	1205	1200	1190	1185	1175	1170	
LOAD CAPACITY @ 30 FPM (LBS)								
HP	WIDTH							
	12"	18"	24"	30"	36"	42"	48"	
1/2	600	590	585	580	575	570	560	
3/4	905	900	895	890	880	875	870	
1	1210	1205	1200	1195	1185	1180	1175	
1 1/2	-	1815	1810	1805	1800	1790	1785	
2	-	-	2425	2420	2410	2405	2400	

MAXIMUM LOAD PER LINEAR FOOT OF CONVEYOR IS 100 POUNDS - NOT TO EXCEED CAPACITY ABOVE

**MODEL:** MDCS  
**DESCRIPTION:** MEDIUM DUTY CHANNEL SLIDER BED BELT CONVEYOR

LEWCO, INC. IS COMMITTED TO CONTINUOUS IMPROVEMENT AND RESERVES THE RIGHT TO CHANGE DESIGNS AND SPECIFICATIONS WITHOUT NOTICE.  
 THIS DRAWING MUST NOT BE COPIED, REPRODUCED OR USED FOR ANY PURPOSE WITHOUT THE WRITTEN CONSENT OF LEWCO, INC. ALL RIGHTS RESERVED.



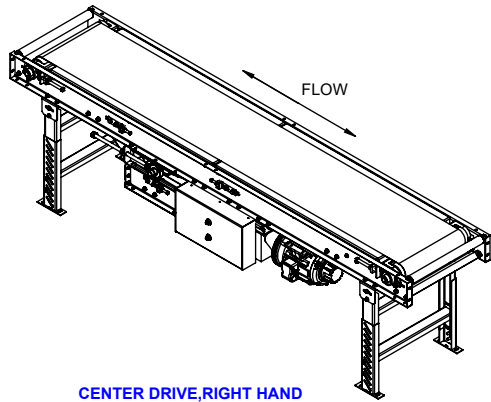

CENTER DRIVE,RIGHT HAND

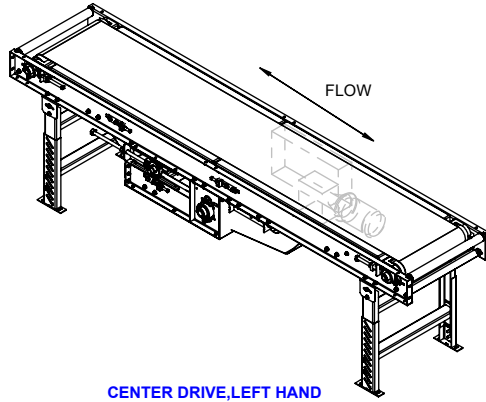

CENTER DRIVE,LEFT HAND

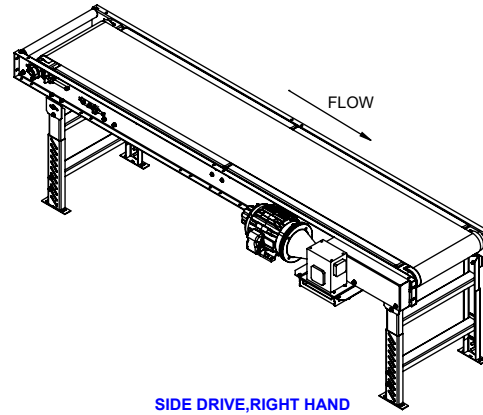

SIDE DRIVE,RIGHT HAND

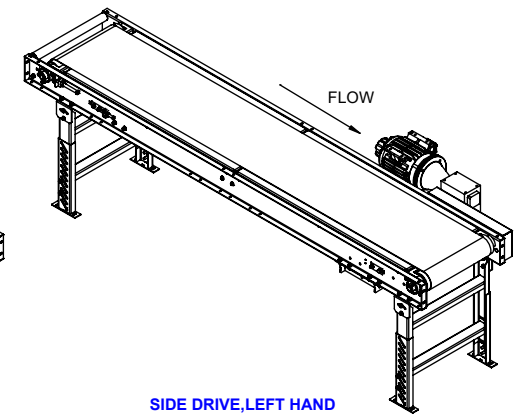

SIDE DRIVE,LEFT HAND

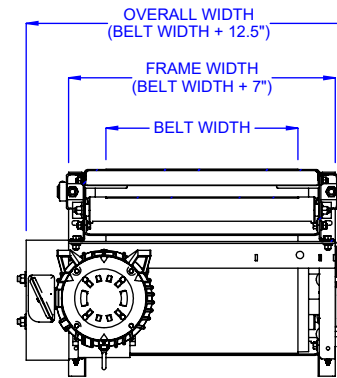
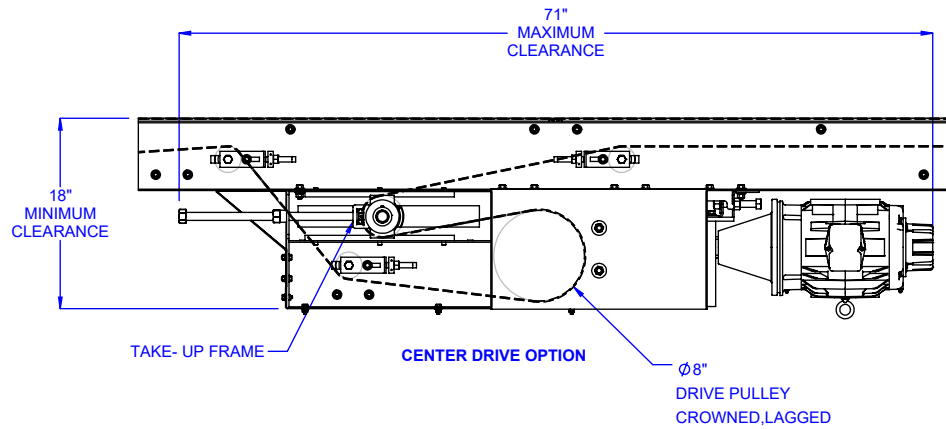

CENTER DRIVE END VIEW

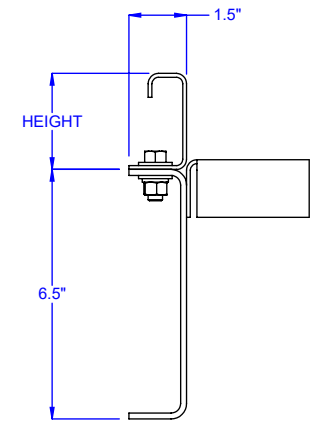

OPTIONAL GUARDRAIL

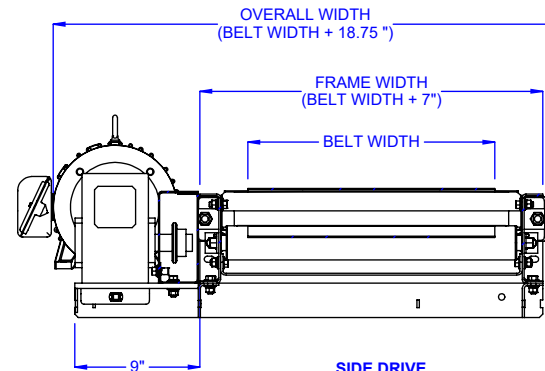
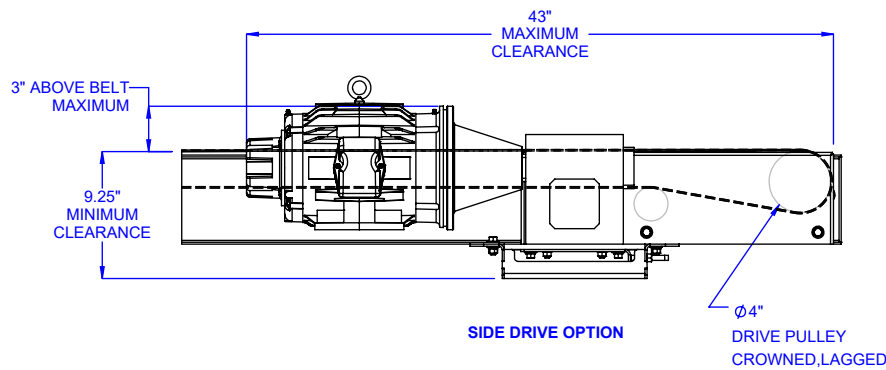

SIDE DRIVE END VIEW

MODEL: MDCS

DESCRIPTION: MEDIUM DUTY CHANNEL SLIDER BED BELT CONVEYOR

LEWCO, INC. IS COMMITTED TO CONTINUOUS IMPROVEMENT AND RESERVES THE RIGHT TO CHANGE DESIGNS AND SPECIFICATIONS WITHOUT NOTICE.

THIS DRAWING MUST NOT BE COPIED, REPRODUCED OR USED FOR ANY PURPOSE WITHOUT THE WRITTEN CONSENT OF LEWCO, INC. ALL RIGHTS RESERVED.



706 LANE ST. SANDUSKY, OH 44870, U.S.A.

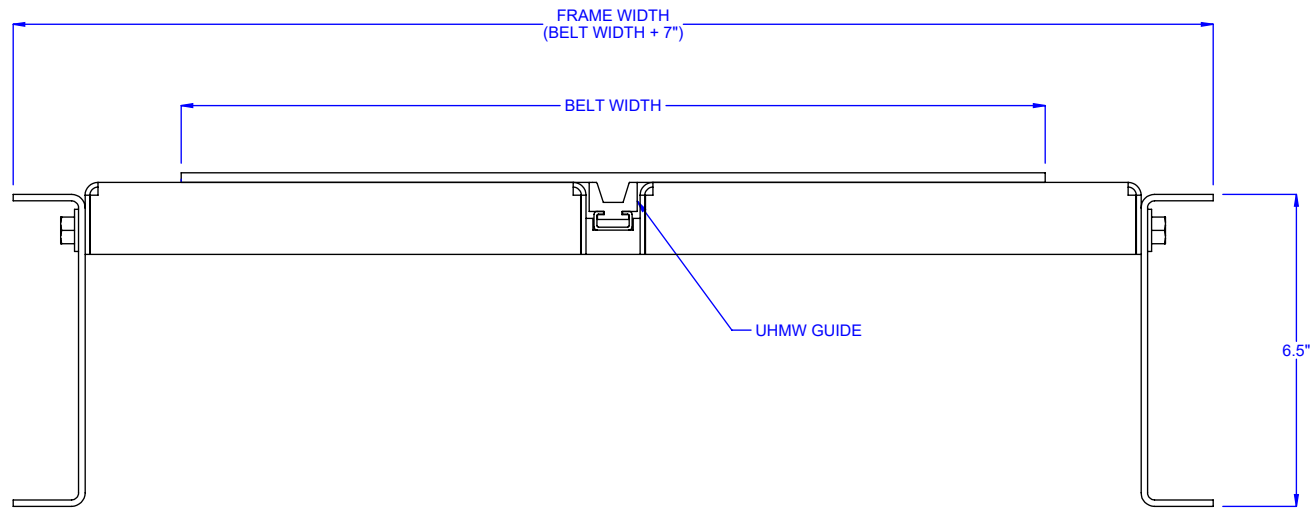

**OPTIONAL V-GUIDED CONSTRUCTION**  
 (NOTE: PULLEYS ARE GROOVED TO ACCOMMODATE THE V-BELT)

**MODEL:** MDCS

**DESCRIPTION:** MEDIUM DUTY CHANNEL SLIDER BED BELT CONVEYOR

LEWCO, INC. IS COMMITTED TO CONTINUOUS IMPROVEMENT AND RESERVES THE RIGHT TO CHANGE DESIGNS AND SPECIFICATIONS WITHOUT NOTICE.

THIS DRAWING MUST NOT BE COPIED, REPRODUCED OR USED FOR ANY PURPOSE WITHOUT THE WRITTEN CONSENT OF LEWCO, INC. ALL RIGHTS RESERVED.



706 LANE ST. SANDUSKY, OH 44870, U.S.A.