

## 40SB – Low Profile Slider Bed

Model 40SB is LEWCO's most economical slider bed belt conveyor. It provides a reliable way of transporting products in assembly, sorting, testing, and packaging applications. These slider bed belt conveyors are the most popular of all powered conveyors due to their simple, economical design.

### Belt Width

- 12", 18", 24", 30", 36"

### Length

- 48" to 600"

### Belt

- PVC120 EMB embossed cover with clipper lacing.
- Optional:
  - PVC120 smooth top
  - PVC150 rough top
  - PVC120, Black, friction both sides
  - PVC Food grade, White
  - Thermoplastic polyurethane (TPU) Covered Belt
  - PVC longitudinal groove
  - No Belt
- V-Guided Belt or Troughed Belts design also available.

### Drive Location

- End Drive, Bottom Right
- Optional:
  - End Drive, Bottom, Left
  - End Drive, Side, Right or Left
  - Center Drive, Right or Left (standard for conveyors with reverse)

### Motor

- 1/2 HP to 1-1/2 HP
- Totally Enclosed Fan Cooled motor
- Optional:
  - Inverter Duty motor
  - Power Off Brake motor
- Voltage: 230/460/ 3Ph/ 60hz
- Optional:
  - 115V/ 1Ph/ 60Hz
  - 208V/ 1Ph/ 60Hz
  - 230V/ 1Ph/ 60Hz
  - 575V/ 3Ph/ 60Hz
  - 90V DC

### Speed

- 15 to 300 FPM (feet per minute)
- Reverse capability optional

### Control Options

- No controls (provided by others)
- Variable Speed Controller
- Combination motor starter with disconnect, fixed speed
- Combination motor starter with disconnect, variable speed
- PLC with HMI

### Conveyor Color

- Blue (RAL 5017)
- Guards are yellow (RAL 1023)
- Moving parts are bright red orange (RAL 2008).
- Optional:
  - Light Gray (RAL 7035)
  - Repose Gray (not an RAL)
  - Patina Green (RAL 6000)
  - Signal White (RAL 9003)
  - Jet Black (RAL 9005)
  - Flat Black (not an RAL)
  - Custom colors available

### Additional Options

- Conveyor Supports with or without casters
- Guardrail
- Photo Eye Sensor(s)
- Custom sizes and features available. Please consult a LEWCO Applications Engineer for more information.

### Quality Assurance

- Each unit comes complete with a (1) year warranty.
- Manufactured under ISO 9001 Quality Certified System.

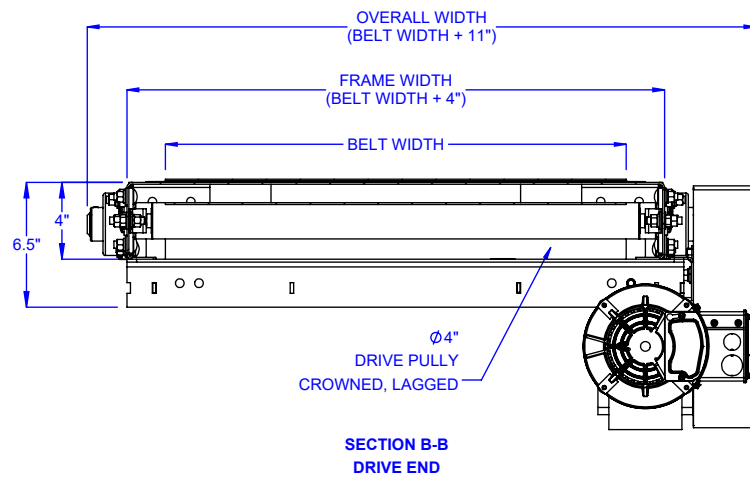
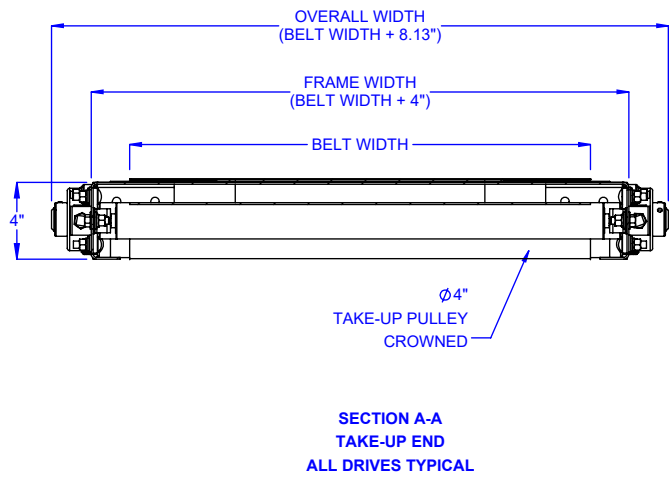
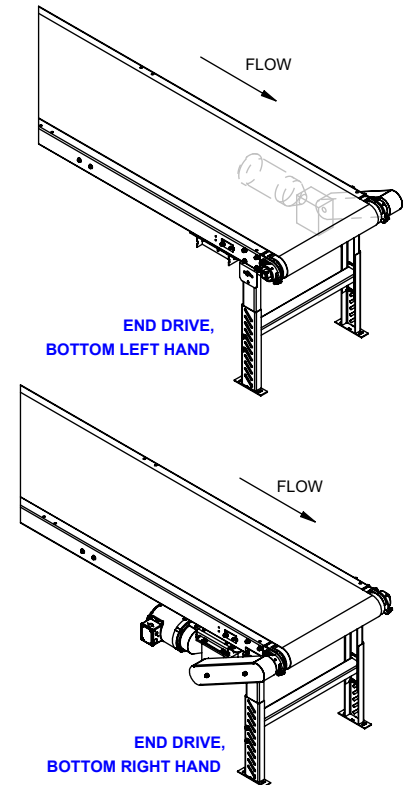
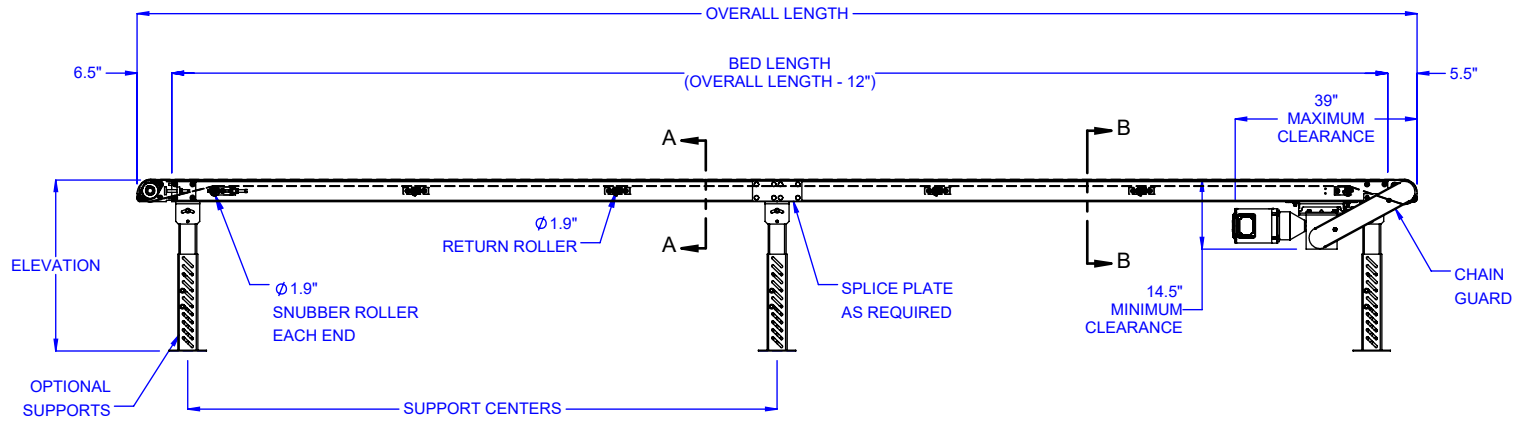

LOAD CAPACITY @ 60 FPM (LBS)					
HP	WIDTH				
	12"	18"	24"	30"	36"
1/2	290	285	280	270	265
3/4	445	440	435	425	420
1	600	590	585	580	570
1 1/2	900	895	885	880	870
LOAD CAPACITY @ 30 FPM (LBS)					
HP	WIDTH				
	12"	18"	24"	30"	36"
1/2	600	595	590	580	575
3/4	910	900	895	890	880
1	1215	1205	1200	1195	1185
1 1/2	-	1820	1810	1805	1800

**MAXIMUM LOAD PER LINEAR FOOT OF CONVEYOR IS 75 POUNDS - NOT TO EXCEED CAPACITY ABOVE**

**MODEL:** 40SB  
**DESCRIPTION:** LOW PROFILE SLIDER BED BELT CONVEYOR

LEWCO, INC. IS COMMITTED TO CONTINUOUS IMPROVEMENT AND RESERVES THE RIGHT TO CHANGE DESIGNS AND SPECIFICATIONS WITHOUT NOTICE.

THIS DRAWING MUST NOT BE COPIED, REPRODUCED OR USED FOR ANY PURPOSE WITHOUT THE WRITTEN CONSENT OF LEWCO, INC. ALL RIGHTS RESERVED.



706 LANE ST. SANDUSKY, OH 44870, U.S.A.

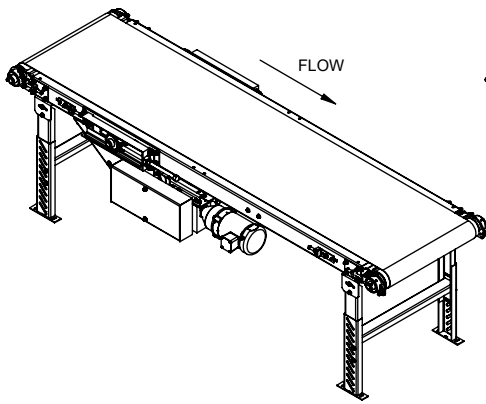

CENTER DRIVE, RIGHT HAND

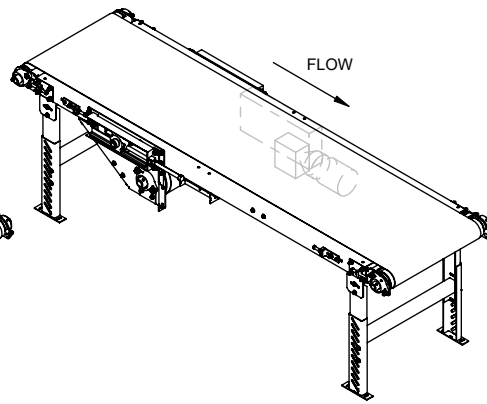

CENTER DRIVE, LEFT HAND

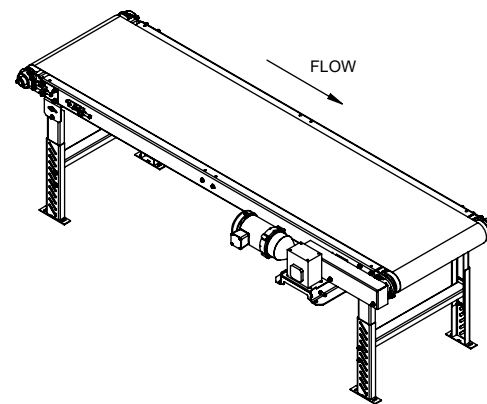

SIDE DRIVE, RIGHT HAND

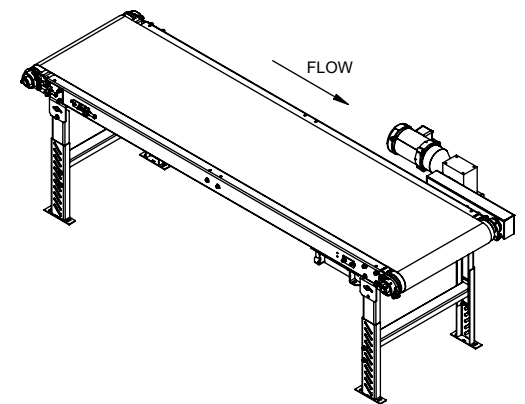

SIDE DRIVE, LEFT HAND

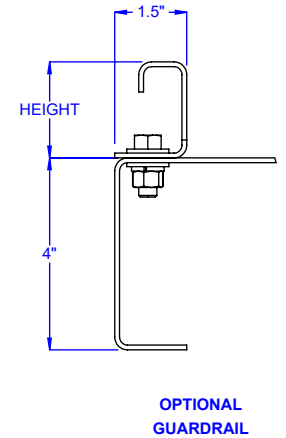
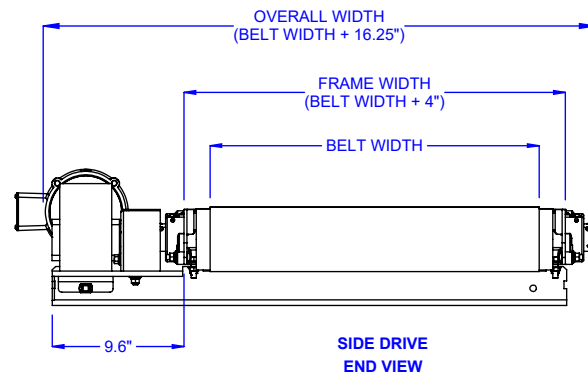
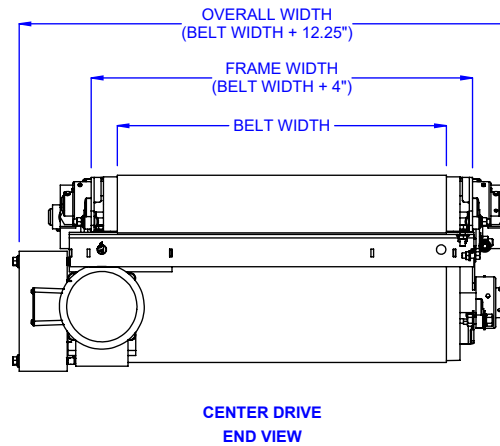
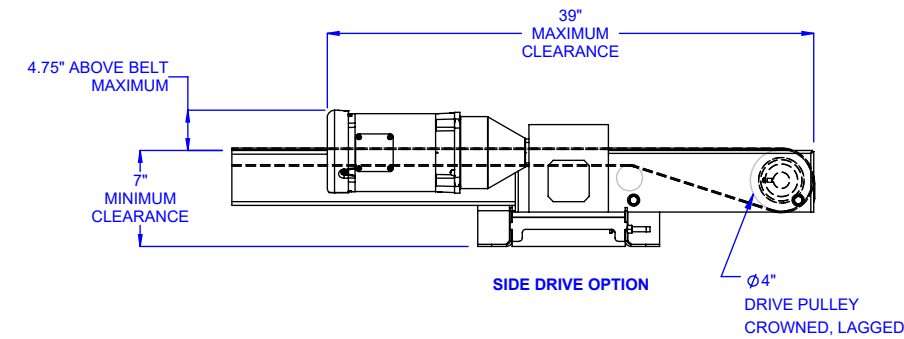
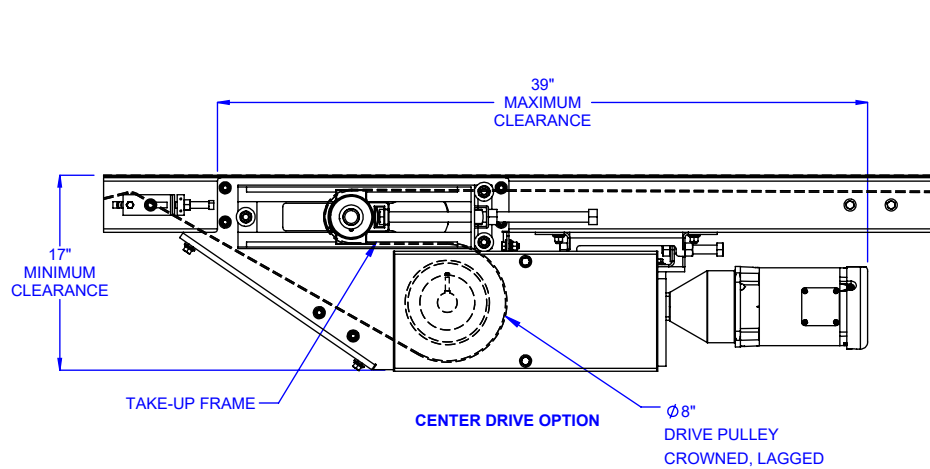

MODEL: 40SB

DESCRIPTION: LOW PROFILE SLIDER BED BELT CONVEYOR

LEWCO, INC. IS COMMITTED TO CONTINUOUS IMPROVEMENT AND RESERVES THE RIGHT TO CHANGE DESIGNS AND SPECIFICATIONS WITHOUT NOTICE.

THIS DRAWING MUST NOT BE COPIED, REPRODUCED OR USED FOR ANY PURPOSE WITHOUT THE WRITTEN CONSENT OF LEWCO, INC. ALL RIGHTS RESERVED.

**LEWCO**

706 LANE ST. SANDUSKY, OH 44870, U.S.A.

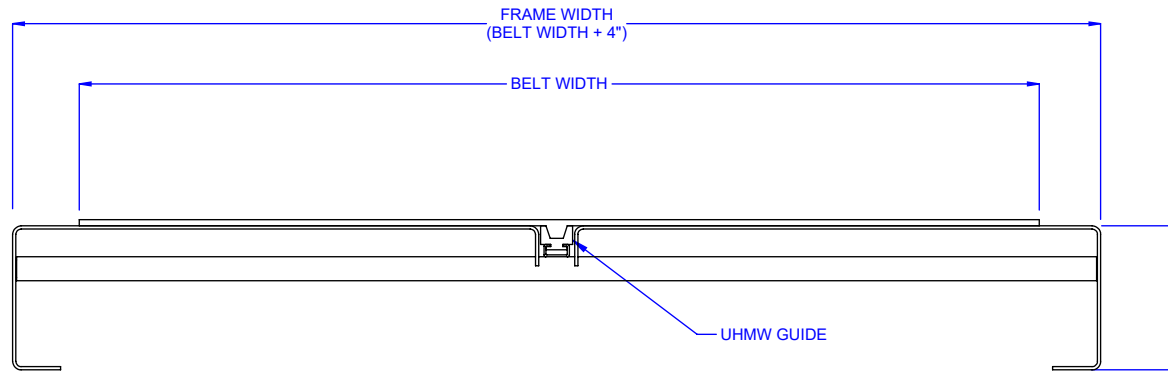

**OPTIONAL V-GUIDED CONSTRUCTION**  
 (NOTE: PULLEYS ARE GROOVED TO ACCOMMODATE THE V-BELT)

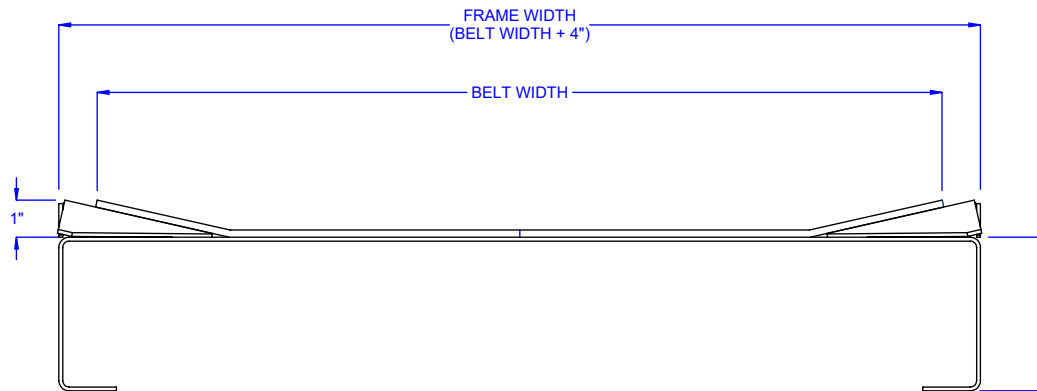

**OPTIONAL TROUGH CONSTRUCTION**

**MODEL:** 40SB

**DESCRIPTION:** LOW PROFILE SLIDER BED BELT CONVEYOR

LEWCO, INC. IS COMMITTED TO CONTINUOUS IMPROVEMENT AND RESERVES THE RIGHT TO CHANGE DESIGNS AND SPECIFICATIONS WITHOUT NOTICE.

THIS DRAWING MUST NOT BE COPIED, REPRODUCED OR USED FOR ANY PURPOSE WITHOUT THE WRITTEN CONSENT OF LEWCO, INC. ALL RIGHTS RESERVED.