

**LOAD CAPACITY:**  
**3000 LB. MAXIMUM LOAD PER SUPPORT**  
**NOT TO EXCEED LOAD CAPACITY OF CASTERS**

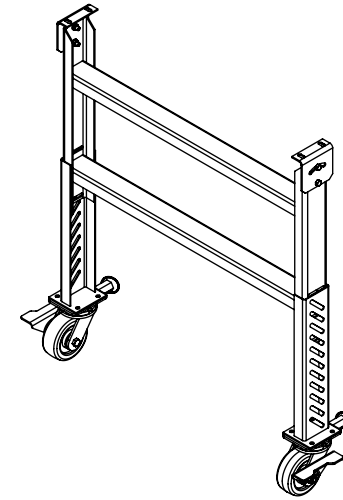
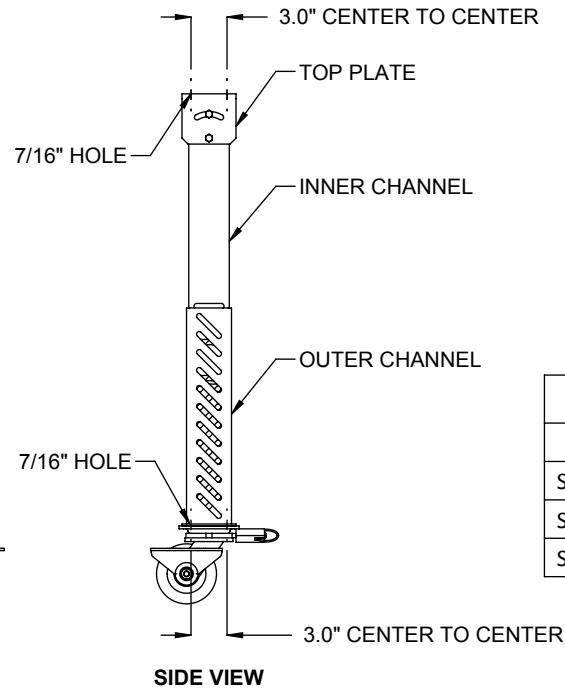
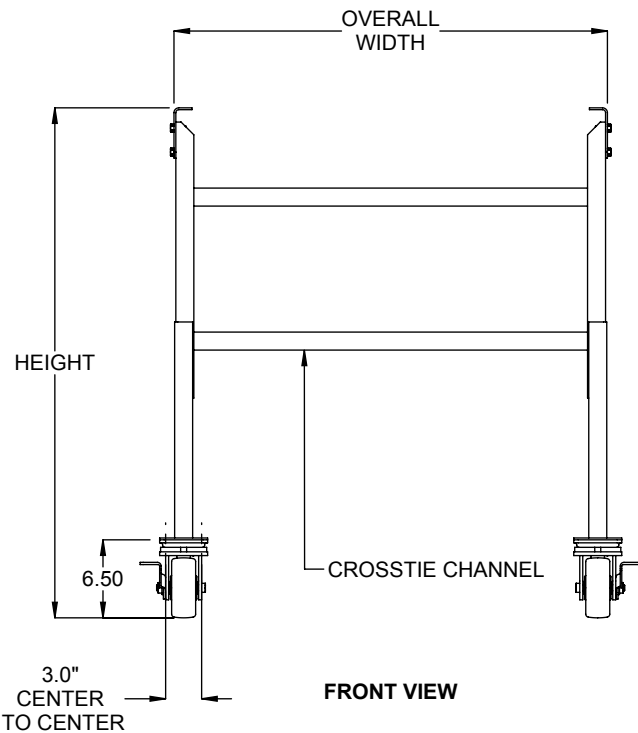

SPHC5:								
MODEL	MIN.	MAX.	MODEL	MIN.	MAX.	MODEL	MIN.	MAX.
SPHC5-20	19.25"	20.75"	SPHC5-29	23.25"	29.25"	SPHC5-40	29.25"	40.25"
SPHC5-23	20.25"	23.25"	SPHC5-33	27.25"	33.25"	SPHC5-43	31.25"	43.25"
SPHC5-25	21.25"	25.25"						

SPECIFICATIONS	
<b>OVERALL WIDTH:</b> 15" - 80"	
<b>CONSTRUCTION:</b> Formed steel inner, 8ga and outer channels, 12ga; Welded channel crosstie, 12ga; Base plate, 8ga.	
<b>CASTER:</b> <u>Standard</u> 5" x 2" with swivel lock and brake.	
<b>TOP PLATE:</b> <u>Standard</u> 8ga pivot top plate is available where adjustable pitch is required.	
<b>FINISH:</b> <u>Standard</u> finish is OSHA safety blue powder. <u>Optional</u> colors include green, beige, gray, orange, black and yellow.	

**Model:** SPHC5 - Support, Heavy Duty, 5", Caster Mount

REV	<b>LEWCO</b>
0	