

**END DRIVE, RIGHT HAND (SHOWN)
END DRIVE, LEFT HAND (OPPOSITE)**

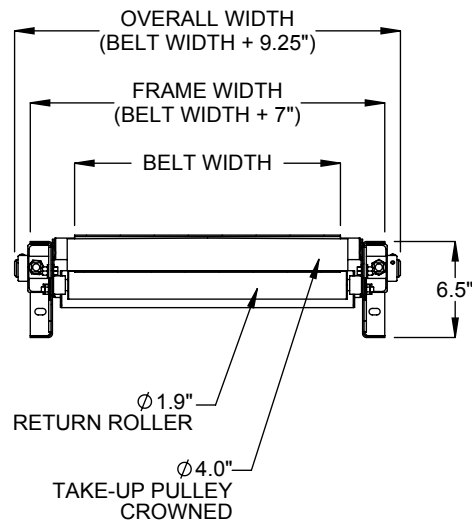

**SECTION A-A
TAKE-UP END
TYPICAL ALL DRIVES**

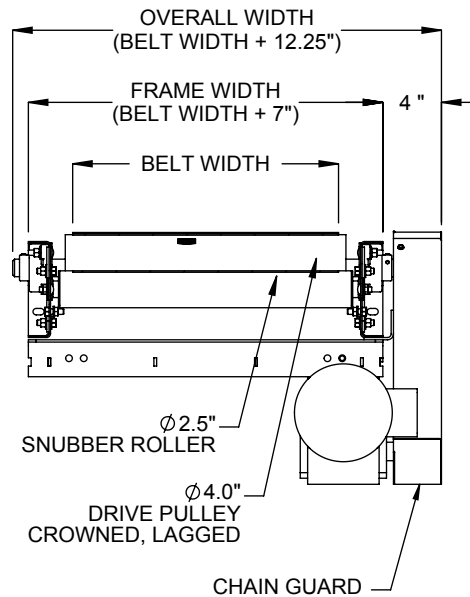

**SECTION B-B
DRIVE END**

SPECIFICATIONS

BELT WIDTH: 12", 18", 24", 30", 36" 42" 48"

BEGINNING ELEVATION: 6.75" - 126" **LENGTH:** 60" - 1200"

ENDING ELEVATION: 6.75" - 126" **SPEED:** 15 - 200 FPM

ROLLER CENTERS: 3", 4.5", 6"

ROLLERS: 1.9" diameter, 16ga wall tubes with 7/16" hex cold rolled steel axle spring retained. Precision grease packed bearings.

BELT: Standard is Trackmate 120 EMB embossed cover with clipper lace. Optional belts include Trackmate rough top, Trackmate friction cover, Trackmate longitudinal groove, food grade white PVC & plied rubber slip top. Other belt options available.

DRIVE: Standard drive is an End drive, right hand side. Optional drives include End drive left hand side, Side drive right or left hand side, or Center drive right or left hand side.

MOTOR: 1/2 HP through 2 HP. Energy efficient, inverter duty & brake motors also available. Voltages include 120/1/60, 230/3/60, 460/3/60, 575/3/60 & DC voltage.

SUPPORT CENTERS: Standard supports are floor supports on 10' centers. Optional floor supports on 5' centers; ceiling supports on 5' & 10' centers.

GUARDRAIL: Optional 2.5", 4.0" & 6.0"; 12ga bolt on channel.

FRAME FINISH: Standard finish is OSHA safety blue powder. Optional colors include green, beige, gray, orange, black and yellow.

Model: MDRB - Medium Duty Roller Bed Belt Conveyor

REV

3



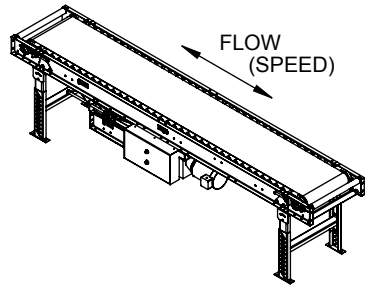

CENTER DRIVE, RIGHT HAND (SHOWN)
CENTER DRIVE, LEFT HAND (OPPOSITE)

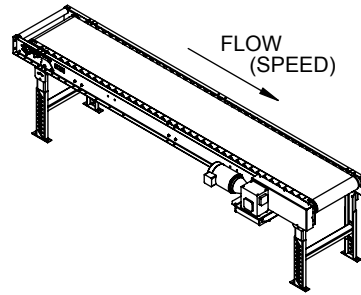

SIDE DRIVE, RIGHT HAND (SHOWN)
SIDE DRIVE, LEFT HAND (OPPOSITE)

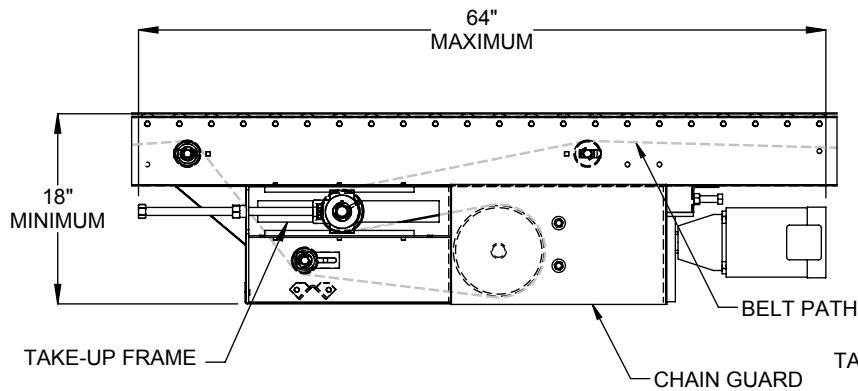

CENTER DRIVE OPTION

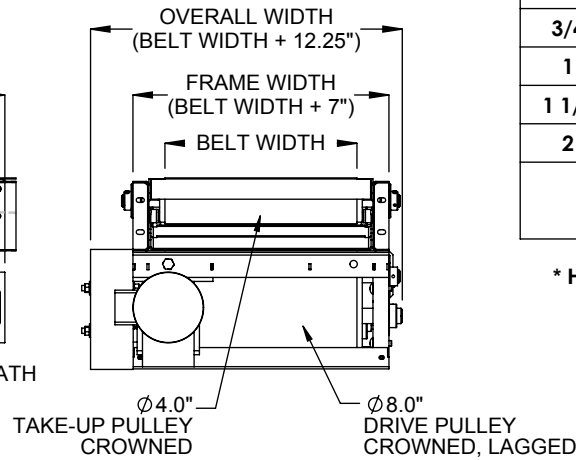

CENTER DRIVE
END VIEW

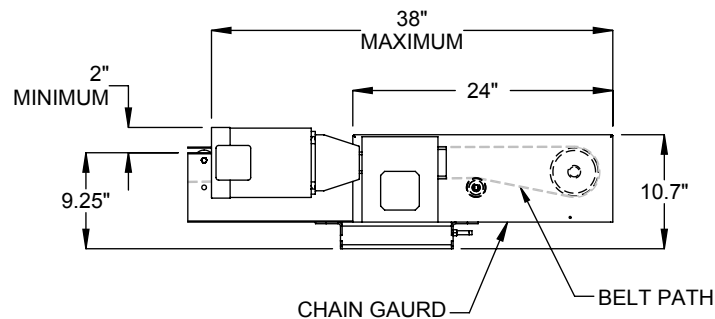

SIDE DRIVE OPTION

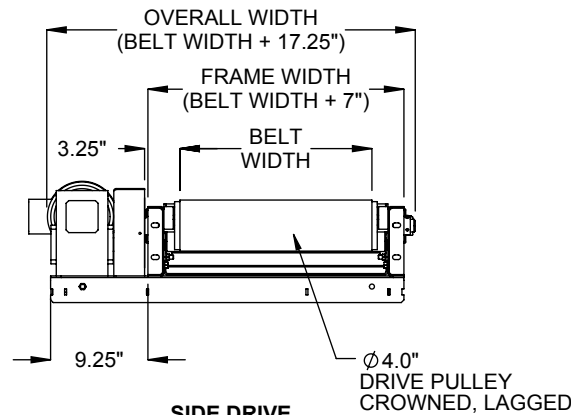

SIDE DRIVE
END VIEW

A
2.5"
4.0"
6.0"

GUARD RAIL OPTION

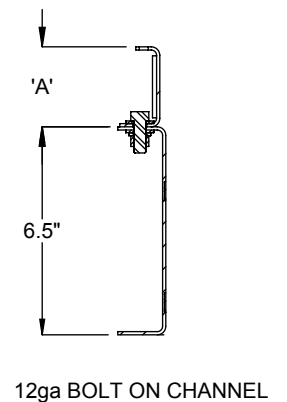

12ga BOLT ON CHANNEL

LOAD CAPACITY @ 60 FPM (LBS)							
HP	WIDTH						
	12"	18"	24"	30"	36"	42"	48"
1/2	725	690	660	625	590	560	525
3/4	1135	1100	1065	1135	1000	965	935
1	1540	1510	1475	1445	1410	1375	1345
1 1/2	2360	2325	2295	2260	2225	2195	2160
2	3175	3145	3110	3080	3045	3010	2980

LOAD CAPACITY @ 30 FPM (LBS)							
HP	WIDTH						
	12"	18"	24"	30"	36"	42"	48"
1/2	1550	1515	1485	1450	1415	1385	1350
3/4	2370	2335	2300	2270	2235	2200	2170
1	3185	3150	3120	3085	3050	3020	2985
1 1/2	-	4785	4755	4720	4685	4655	4620
2	-	-	6390	6355	6320	6290	6255

MAXIMUM LOAD PER LINEAR FOOT OF CONVEYOR IS 225 POUND - NOT TO EXCEED CAPACITY ABOVE

* HP requirements may be slightly higher for closer roll centers.

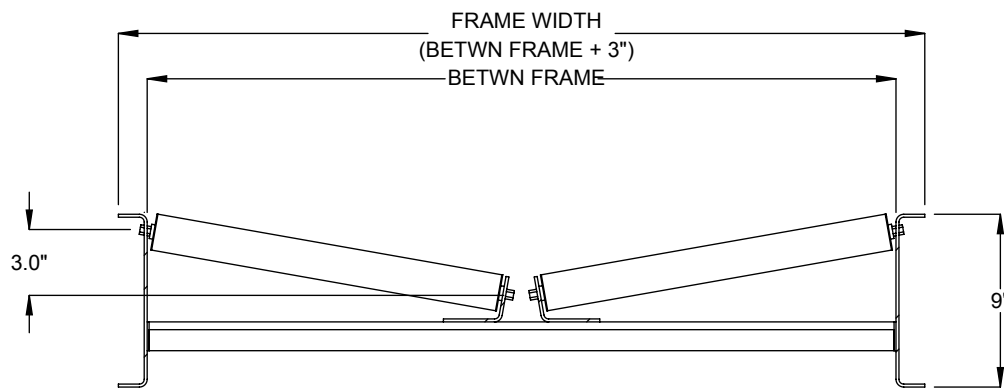

OPTIONAL TROUGH CONSTRUCTION

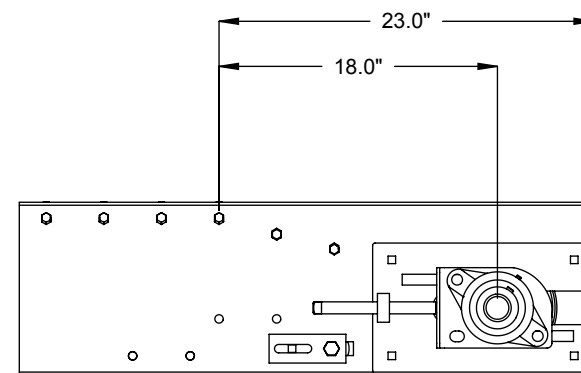

END VIEW