

FRAME CONSTRUCTION FOR
7" - 27" BF

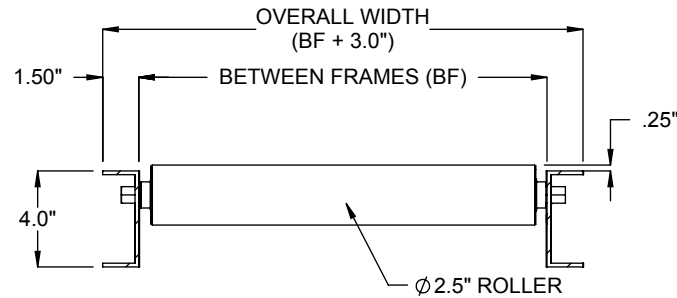

SECTION A-A

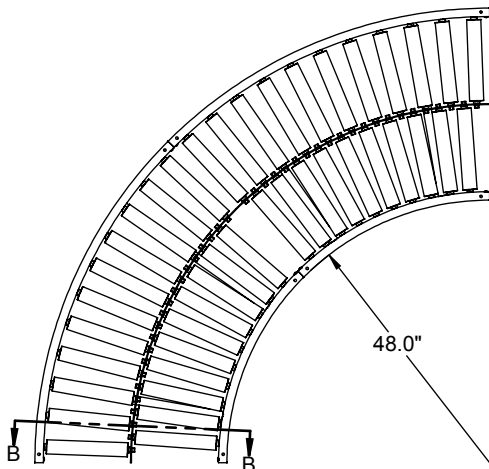
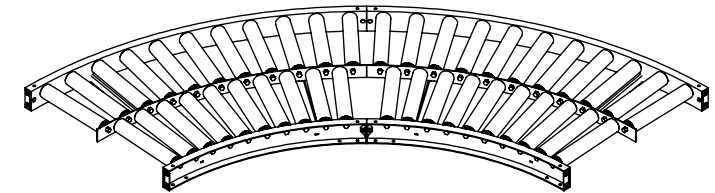
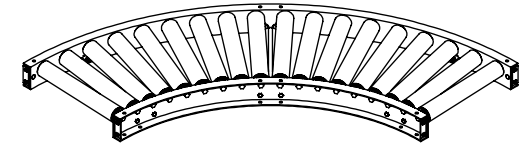

FRAME CONSTRUCTION FOR
OVER 27" BF

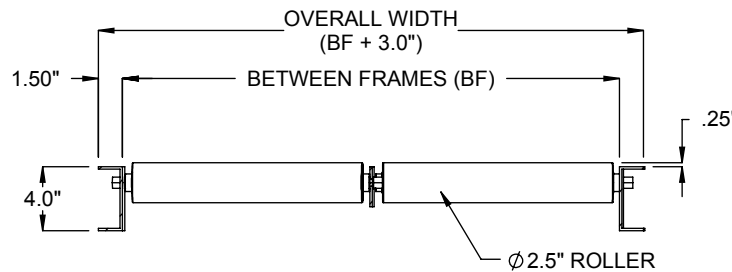

SECTION B-B

NOTE : FOR BF 31" AND LARGER, 90 DEGREE
CURVE SHIPS AS (2) 45 DEGREE CURVES.
SUPPORT AT SPLICE JOINT IS REQUIRED.

SPECIFICATIONS

BETWEEN FRAMES: 6" - 61"	DEGREE: 90°, 45°, 30°
ROLLERS: 2511 Roller - 2.5" dia., 11ga wall tubes. 2607 Roller - 2.625" dia., 7ga wall tubes. Both rollers have 11/16" hex cold rolled steel axle, spring retained. Standard A50 bearings are light oil lubricated. Optional bearings include combinations of precision, semi-precision and non-precision construction with light oil or grease packed lubrication. 750 lbs roller capacity.	
FRAMES: Standard FC96 set high 4" x 1-1/2" x 8ga formed steel channel with bolted 2" x 8ga galvanized angle crossies. Optional frames include FC19 channel 5" & 4" x 1-1/2" x 8ga set high and low or FC39 channel 5" x 1-1/2" x 8ga set low.	
ROLLER SURFACE: Optional Orange Polyurethane, 1/8" wall or galvanized tube. (2511 ONLY)	
COUPLINGS: Bolted butt couplers standard on both ends of channel.	
FRAME FINISH: Standard finish is OSHA safety blue powder. Optional colors include green, beige, gray, orange, black and yellow.	

Model: 2511C - Gravity Roller Conveyor, 2.5 diameter 11 gauge roller
2607C - Gravity Roller Conveyor, 2.625 diameter 7 gauge roller

REV

1

LEWCO